



PC, DVI, HDMI, VIDEO INTERFACE CONTROLLER FOR TFT PANEL

Model: SGX-1920

Part number : 41725001X-3 or up

INSTRUCTIONS

CONTENTS

- Page: **2. Introduction, How to Proceed, Usage Note, Disclaimer**
3. System design – Diagram of a suggested system
4. Assembly notes – Important information about system elements
7. Connection & Operation – How to use the controller
14. Connectors, pinouts & jumpers – Essential connection information
26. Controller dimensions
27. Application notes
29. Troubleshooting
30. Specifications
31. Appendix I – Supported graphics modes table
34. Appendix II – RS-232 control protocols
51. Appendix III – Mapping definition
55. Appendix IV – Auto Color Gain
56. Appendix V – DV remote control unit work for SVX-1920
57. Appendix VI – Function description for de-interlacing mode AFM, TNR, MADI, DCDi
57. Appendix VII – PIP mix table
58. Appendix VIII - Network connection
59. Appendix IX – Digital Ports selection on SGX-1920
64. Appendix X - Specification for inverter Interface Board P/N 416040010-3
67. Appendix XI - Specification for audio add-on board P/N 416940020-3
69. Warranty, Caution & Limitation of Liability, Trademarks
70. Contact details

It is essential that these instructions are read and understood before connecting or powering up this controller.

Introduction

Designed for LCD monitor and other flat panel display applications, the SGX-1920 is a feature rich interface controller for :

- TFT (active matrix) LCD panels of 1920x1200, 1920x1080, 1920x480, 1680x1050, 1600x1200, 1600x900, 1440x900, 1366x768, 1280x1024, 1280x800, 1280x768 1024x768, 1024x600, 800x600, 800x480 and 640x480 resolutions.
- Computer video signals of VGA, SVGA, XGA, SXGA, WXGA, UXGA, WUXGA standard.
- Video signals of NTSC, PAL and SECAM standard.
- Dual digital input port (DVI / HDMI / Auxiliary digital video inputs) support up to 1920x1200 60Hz input signals
- Support HDMI input
- Support true 10 bits panel
- Support HDMI, DVI, VGA, S-Video, Composite Video input
- Support on screen marker

Ordering information :

| Controller | Part number | Ordering part number |
|------------|-----------------|----------------------|
| SGX-1920 | P/N 41726001X-3 | P/N 4172600XX-3 |

HOW TO PROCEED

- Ensure you have all parts & that they are correct, refer to:
 - Connection diagram

Controller Solution Generator

Full web resource matching controllers & panels with **connection diagrams** for download.
See at : <http://www.digitalview.com/csg>

- Connector reference (in following section)
- Assembly notes
- Check controller switch & jumper settings (errors may damage the panel)
- Prepare the PC
- Connect the parts
- Understand the operation & functions

IMPORTANT USAGE NOTE

This equipment is for use by developers and integrators, the manufacturer accepts no liability for damage or injury caused by the use of this product. It is the responsibility of the developer, integrators or other user of this product to:

- Ensure that all necessary and appropriate safety measures are taken.
- Obtain suitable regulatory approvals as may be required.
- **Check power settings to all component parts before connection.**

DISCLAIMER

There is no implied or expressed warranty regarding this material.

SYSTEM DESIGN

A typical LCD based display system utilizing this controller is likely to comprise the following:

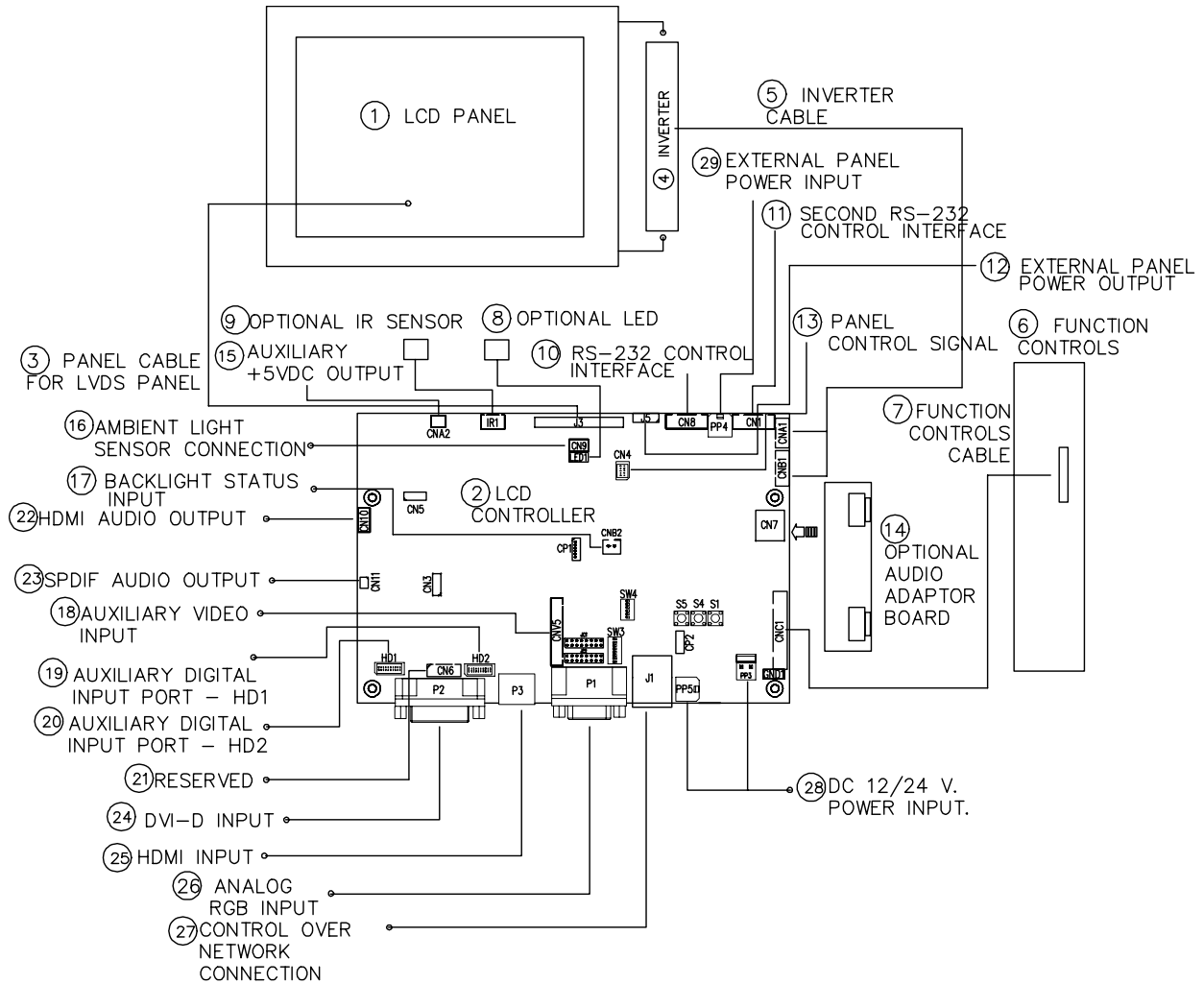

Summary:

1. LCD panel
2. LCD controller card, SGX-1920
3. LCD signal cable (use for LVDS panel)
4. Inverter for backlight (if not built into LCD)
5. Inverter cable
6. Function controls
7. Function controls cable
8. Status LED (optional)
9. IR sensor (optional)
10. RS-232 control interface
11. Second RS-232 control interface
12. External panel power output
13. Panel control signal
14. Audio add-on board (optional)
15. Auxiliary +5VDC, max 500mA output
16. Ambient light sensor connection
17. Backlight status input
18. Auxiliary Video input
19. Auxiliary Digital Input Port – HD1
20. Auxiliary Digital Input Port – HD2
21. Reserved
22. HDMI Audio output
23. SPDIF Audio output
24. DVI-D input
25. HDMI input
26. Analog RGB input
27. Control over network connection
28. +12V / +24V DC power input
29. External panel power input

Digital View provides a range of parts, such as listed above, to make up complete display solutions.

Specifications subject to change without notice

ASSEMBLY NOTES

This controller is designed for monitor and custom display projects using 1920x1200 or 1920x1080 or 1600x1200 or 1680x1050 or 1440x900 or 1366x768 or 1280 x 1024 or 1024 x 768 or 800x600 or 640x480 resolution TFT panels with a VGA, SVGA, WXGA, XGA, SXGA, UXGA or WUXGA signal input. The following provides some guidelines for installation and preparation of a finished display solution.

Preparation: Before proceeding it is important to familiarize yourself with the parts making up the system and the various connectors, mounting holes and general layout of the controller. As much as possible connectors have been labeled. Guides to connectors and mounting holes are shown in the following relevant sections.

- 1. LCD Panel:** This controller is designed for typical LVDS interfaced panels with panel voltage 3.3V, 5V, 12V or 18V, External for 12V~18V interface. Due to the variation between manufacturers of panels signal timing and other panel characteristics, factory setup and confirmation should be obtained before connecting to a panel. **(NOTE: Check panel power jumper settings before connection)**
- 2. Controller:** Handle the controller with care as static charge may damage electronic components. Make sure correct jumper and dip switches settings to match the target LCD panel.
- 3. LCD signal cable (LVDS panel):** In order to provide a clean signal it is recommended that LVDS signal cables are no longer than 46cm (18 inches). If those wire cabling is utilized these can be made into a harness with cable ties. Care should be taken when placing the cables to avoid signal interference. Additionally it may be necessary in some systems to add ferrite cores to the cable to minimize signal noise.
- 4. Inverter:** This will be required for the backlight of an LCD, some LCD panels have an inverter built in. As LCD panels may have 1 or more backlight tubes and the power requirements for different panel backlights may vary it is important to match the inverter in order to obtain optimum performance. See Application notes page 27 for more information on connection.
- 5. Inverter Cables:** Different inverter models require different cables and different pin assignment. Make sure correct cable pin out to match inverter. Using wrong cable pin out may damage the inverter.
- 6. Function Controls:** The following section discusses the controls required and the section on connectors provides the detail. The controls are minimal: On/Off, Backlight Brightness (depends on inverter), OSD (5 momentary buttons) analog VR type or (8 momentary buttons) digital type.
The 8 momentary buttons OSD switch mount P/N 416100520-3 or OSD membrane interface P/N 416100120-3 must be used when 24VDC input.
- 7. Function controls cable:** The cables to the function switches should be of suitable quality and length so that impedance does not affect performance. Generally lengths up to 1 meter (3 feet) should be acceptable.
- 8. Status LED:** The pin direction of the LED should be corrected for right colour indication. Red colour stands for standby. Green colours stands for signal on. The status LED is an optional part only, can be unconnected.
- 9. IR sensor:** It is an optional part only, can be unconnected if not using IR remote control. See Appendix V in details.
- 10. RS-232 control interface :** Firmware upgrade and serial control via this interface port.

11. **Second RS-232 control interface** : This interface support controlled under “Programming mode” .
 Press and hold “MENU” button on the OSD switch mount and turn on the controller to enter the “Programming mode”.
 Choose “Set Uart 1 Input Port” shown below :

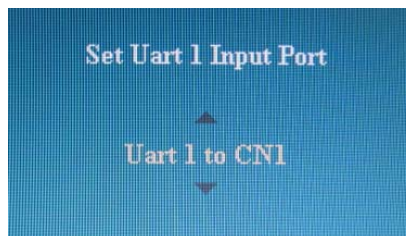
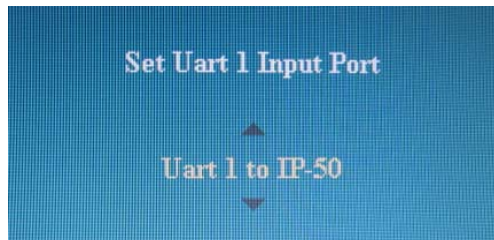
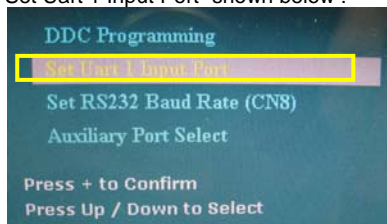

Set “Uart 1 to IP-50” : Enable Ethernet network (J1) support and disable second RS-232 serial control (CN1) support
 Set “Uart 1 to CN1” : Enable second RS-232 serial control (CN1) support. Disable Ethernet network (J1) support

12. **External panel power output** : User for specific panel model.
13. **Panel control signal** : Use for specific panel model.
14. **Audio add-on board P/N 416940020-3**: Provide the interface for the audio add-on board P/N 416940020-3 to be connected. The audio add-on board gives the audio input and output signal connection. The volume can be controlled by the OSD menu on the controller. It is an optional part only, can be unconnected if not using audio.
 CAUTION : The Audio Add-on Board P/N 416940020-3 is only operate under 12VDC power input environment.
15. **Auxiliary +5VDC output** : 2 ways connector provides +5VDC output.
16. **Ambient light sensor connection** : 3 ways connector provides interface for ambient light sensor connection by using Kit 70220-3.
17. **Backlight status input** : 2 ways connector provides interface for connection with the specific panel type which support the panel with backlight status monitoring function.
18. **Auxiliary video input** : It provides alternate video input for S-Video 1, Composite Video 1 & Component Video 1. And it also provide S-Video 2, Composite Video 2 & Component Video 2 input. Plug the auxiliary video cable P/N 426301700-3 on CNV5 connector.
19. **Auxiliary Digital Input Port – HD1** : Support Digital video signal input (e.g HDMI, DVI, HD-SDI (from HD-1000/-2000/-3000/-3000S)). Please refer to Appendix IX to configure this auxiliary digital input port – HD1. Reasonable quality cable should be used to avoid image quality degradation.
20. **Auxiliary Digital Input Port – HD2** : Support Digital video signal input (e.g HDMI, DVI, HD-SDI (from HD-1000/-2000/-3000/-3000S)). Please refer to Appendix IX to configure this auxiliary digital input port – HD2. Reasonable quality cable should be used to avoid image quality degradation.
21. **Reserved** : No function, reserved for future development.
22. **HDMI audio output** : Support HDMI audio with stereo output.
 The HDMI audio output can be connected to Audio add-on board P/N 416940020-3 by using the audio cable P/N 426451800-3 (310mm) connected between SGX-1920 (connector : CN10) and Audio add-on board P/N 416940020-3 (connector : CN2).
23. **SPDIF Audio output** : This port support SPDIF audio output from the HDMI audio source inputted.
24. **DVI-D input cable** : Plug the DVI cable to the connector P3 on the controller board.
25. **HDMI input** : Plug the HDMI cable to the connector P2 on the controller board. This port is not supported when CN5 is connected.
26. **Analog RGB Input** : As this may affect regulatory emission test results and the quality of the signal to the controller a suitably shielded cable should be utilized.
27. **Control over network connection** : This is a network device that allow to control RS-232 enable devices over a TCP/IP based Ethernet and the Internet using a web browser. Please refer to Appendix VIII in details.
28. **Power Input**: 12V/24VDC is required, this should be a regulated supply. The power rating is depending on the panel and

Specifications subject to change without notice

inverter used. Normally, power supply with 3.5Amp current output should be enough for most of 4x CCFT panels. Although the controller provides power regulation for the LCD power this does not relate to the power supplied to the backlight inverter. If an unregulated power supply is provided to an inverter any fluctuations in power may affect operation, performance and lifetime of the inverter and or backlight tubes.

29. External panel power input : Allow to supply external power to the panel separately for max 3.3V (7A) or 5V (7A) or 12V (5A) or 18V (3.5A) via PP4 power input connector. Corresponding jumper setting of JA3, JA5 & JA6 are required for each panel power input by referring to page 17.

- **Power output:** Note the controller has an overall 3Amp current limit and the current available from the auxiliary power output will be dependent on the power input and other system requirements.
- **Power Safety:** Note that although only 12V / 24VDC is required as 'power-in' a backlight inverter for panel backlighting produces significantly higher voltages (the inverter does not connect to the ground plane). We strongly advise appropriate insulation for all circuitry.
- **EMI:** Shielding will be required for passing certain regulatory emissions tests. Also the choice of external Controller to PC signal cable can affect the result.
- **Ground:** The various PCB mounting holes are connected to the ground plane.
- **Servicing:** The board is not user serviceable or repairable. Warranty does not cover user error in connecting up to the controller and is invalidated by unauthorized modification or repairs.
- **Controller Mounting:** It is recommended that a clearance of at least 10mm is provided above and 5mm below the controller when mounted. Additionally consideration should be given to:
 - Electrical insulation.
 - Grounding.
 - EMI shielding.
 - Cable management. Note: It is important to keep panel signal cables apart from the inverter & backlight cables to prevent signal interference.
 - Heat & Ventilation: Heat generated from other sources, for example the backlight of a very high brightness panel may generate significant heat which could adversely affect the controller.
 - Other issues that may affect safety or performance.
- **PC Graphics Output:** A few guidelines:
 - Signal quality is very important, if there is noise or instability in the PC graphics output this may result in visible noise on the display.
 - Refer to graphics modes table in specifications section for supported modes.
 - Non-interlaced & interlaced video input is acceptable.

IMPORTANT: Please read the Application Notes section for more information.

CONNECTION & OPERATION

CAUTION: Never connect or disconnect parts of the display system when the system is powered up as this may cause serious damage.

CONNECTION

Connection and usage is quite straight forward (it is useful to have the relevant connection diagram available at this time):

1. **LCD panel & Inverter:** Connect the inverter (if it is not built-in the panel) to the CCFT lead connector of the LCD panel.
2. **LVDS type panels:** The controller board has the built-in LVDS transmitter driver. Plug the LVDS cable to J3. Insert the panel end of the cable the LCD panel connector.
3. **Inverter & Controller:** Plug the inverter cable to CNB1 and CNA1 (if necessary). Plug another end to the connector on the inverter.
4. **Function switch & Controller:** Plug the OSD switch mount cable to CNC1 on the controller board and another to the OSD switch mount.
5. **LED & Controller:** Plug in a 3-way with dual colour LED to connector LED1 on the controller board.
6. **IR & Controller:** Plug in a 3-way with IR sensor to connector IR1 on the controller board.
7. **Jumpers & Switches:** Check all jumpers and switches (SW3, SW4) are set correctly. Details referring the connection diagram (a separate document) or the jumpers and switches setting table (in the following section).
8. **Jumpers & Inverter & Panel voltage:** Particularly pay attention to the settings of JA3, JA5, JA6, JB2 and JB3. JB2 & JB3 are used for inverter control (read inverter specification and information on the jumper table to define the correct settings). JA3 & JA5 & JA6 is used for panel voltage input (read panel specification and information on the jumper table to define the correct settings).
9. **VGA cable & Controller:** Plug the VGA cable to the connector P1 on the controller board.
10. **Power supply & Controller:** Plug the DC 12V/24V power in to the connector PP5 or PP2/3. You can consider to use DigitalView mating power cable P/N 426013800-3, 160mm for PP5 connection.
11. **External panel power input :** Plug power cable : P/N 426013700-3 for external panel power input (3.3 (max 7A) / 5V (max 7A) / 12V (max 5A) / 18V (max3.5))
12. **Power on:** Switch on the controller board and panel by using the OSD switch mount.
13. **Audio Board :** The Audio Add-on Board P/N 416940020-3 is only operate under 12VDC power input environment.
14. **HDMI audio output :** The HDMI audio output can be connected to Audio add-on board P/N 416940020-3 by using the audio cable P/N 426451800-3 connected between SVX-1920 (connector : CN10) and Audio add-on board P/N 416940020-3 (connector : CN2).
15. **Auxiliary Digital Input Port – HD1 / HD2 :** Allow the user to configure the input port configuration for supporting Digital video signal input (e.g HDMI, DVI, HD-SDI (from HD-1000/-2000/-3000/-3000S)). Please refer to Appendix IX to configure this auxiliary digital input port – HD1 & HD2.

General:

- If you are using supplied cables & accessories, ensure they are correct for the model of panel and controller.
- If you are making your own cables & connectors refer carefully to both the panel & inverter specifications and the section in this manual, "Connectors, Pinouts & Jumpers" to ensure the correct pin to pin wiring.

PC SETTINGS

The controller has been designed to take a very wide range of input signals however to optimize the PC's graphics performance we recommend choosing 60Hz vertical refresh rate – this will not cause screen flicker.

OPERATION

Once the system has been connected and switched on there are a number of functions available to adjust the display image as summarized in the following sections. The settings chosen will be saved for each mode independently.

LCD DISPLAY SYSTEM SETTINGS

NOTE: By way of explanation the following refers to a set of sample buttons that may be obtained as an option. In addition to power on/off and connection for backlight brightness the controller provides an On Screen Display of certain functions which are controlled by 5 momentary type buttons (analog VR type) or 8 momentary type buttons (digital type):

| Controls | Analog VR type | Digital type |
|--|--|--|
| On/Off – turns controller board power on | VR toggle switch | On/Off button |
| Brightness – controls backlight brightness | Rotary VR | Brightness +/- buttons |
| Menu – Turns OSD menu On or Off (it will auto time off) – Back to previous OSD menu page | Menu button | Menu button |
| Select down – Moves the selector to the next function (down) | SEL DN | SEL DN |
| Select up – Moves the selector to the previous function (up) | SEL UP | SEL UP |
| + – Increase the OSD parameter values – Go into the sub-menu page from the top – Confirm to select the OSD function | + | + |
| - – Decrease the OSD parameter values – Go into the sub-menu page from the bottom | - | - |
| Reset to Factory Defaults | Press and hold SEL DN button, then power on the controller | Press and hold SEL DN button, then power on the controller |
| Access "Programming Mode" | Press and hold MENU button, then power on the controller | Press and hold MENU button, then power on the controller |

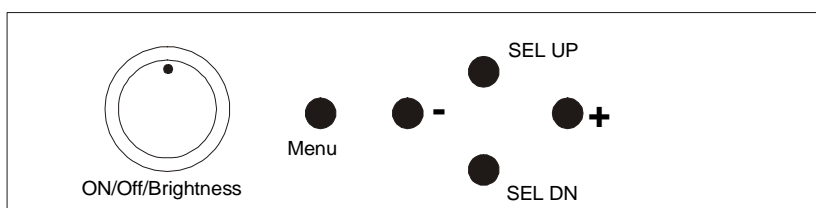

Analog VR type

12V / 24VDC power input :
Analog 10K VR Type OSD
switch mount uses
P/N 410680550-3 or up

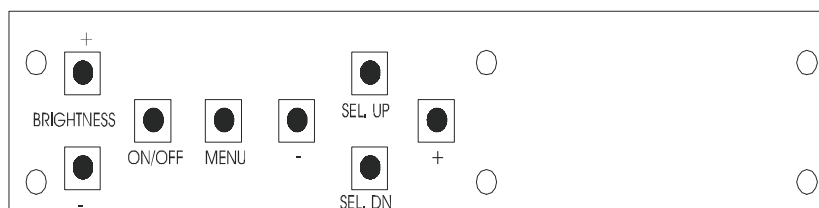

Digital type

12V / 24VDC power input :
Digital 10K Type OSD
switch mount uses
P/N 416100520-3 or up

OSD functions



- Picture :**
- Volume^{###} Increase/decrease volume level, total: 100 steps
 - Brightness Increase/decrease panel brightness level, total: 100 steps
 - Contrast Increase/decrease panel contrast level, total: 100 steps
 - Saturation Increase/decrease saturation, total: 100 steps
 - Hue ^{**} Increase/decrease Hue level, total: 100 steps
 - Sharpness^{*} Increase/decrease sharpness, total: 30 steps
 - Backlight Backlight brightness adjustment (Functions when light detector sets OFF)

Position^{##}



Move the image position upward



Move the image position downward



Move the image position to the left



Move the image position to the right

Aspect / Size ▶

- Fill Screen : Enable full screen expansion for lower resolution Image
- Fill to Aspect Ratio: Enable fill screen expansion for lower resolution image according to aspect ratio
- 4 : 3 : scaling format in 4:3
- 16 : 9 : scaling format in 16:9
- 16 : 10 : scaling format in 16:10
- 2.35 : 1 : scaling format in 2.35:1
- 2 : 1 : scaling format in 2:1
- 1 : 1 : Display the exact image resolution on the screen without image expansion.
- Custom Sizing^{*} : (The name will change depends on the scaling mode selected.)
 - Overscan
 - Normal
 - Custom/Underscan Sizing ▶

- H Size
- V Size
- H Pan
- V Pan

Blue Only ON / OFF : Turn off the "Red" & "Green" channel (i.e. output all zero to Red & Green channel)
 [This function will display on OSD menu when JP4 – 5-6 closed]

^{*} : DISPLAY IN VIDEO MODE ONLY

^{**} : FUNCTION IN ARGB/ DVI / VIDEO NTSC MODE ONLY

[#] : DISPLAY IN ARGB / DVI MODE ONLY

^{##} : FUNCTION IN ARGB MODE ONLY

^{###} : DISPLAY WHEN AUDIO ADD-ON BOARD CONNECTED



Source : Select the input video signal

Main Port Change ▶

- VGA
- DVI⁺
- HDMI⁺
- HD/SD SDI 1⁺⁺
- HD/SD SDI 2⁺⁺
- Composite 1
- Composite 2^{***}
- S-Video 1
- S-Video 2^{***}
- Component 1
- Component 2^{***}

PIP Port change ▶

PIP Off / Composite 1 / Composite 2^{***} / S-Video 1 / S-Video 2^{***} / Component 1 / Component 2^{***} / VGA / DVI⁺ / HDMI⁺ / HD/SD SDI 1⁺⁺ / HD/SD SDI 2⁺⁺)

PIP Size ▶ : Off / PIP Size/ 1~18 / Size by Size / Size by Size Tall

The PIP capability on display input sources refer to Appendix VII – PIP mix table

PIP Position :



Move the PIP position upward



Move the PIP position downward



Move the PIP position to the left



Move the PIP position to the right

PIP Blend Level : 6.25% ~ 100%

PIP Swap : Swap between the main window and PIP window

PIP Auto Turn off : OFF ON : OFF / ON

ON : When PIP is no signal input after 30 seconds, the PIP window will turn off automatically.

OFF : PIP window keeps on

*** DISPLAY WHEN SETTING ON UNDER SETUP → AUTO SOURCE SEEK
+ FUNCTION DISABLE WHEN HD-3000 CONNECTED
++ DISPLAY WHEN HD-3000 CONNECTED



Utilities :

Setup ▶

Auto Picture Setup[#] : Auto adjust the image position, phase and size

Auto Color Gain[#] : Auto Color Calibration (See appendix IV)

Wide Screen Mode detection[#] ▶ : Recognize the wide screen mode coming from ARGB port

- Off
- 1280x768
- 1360x768
- 1366x768

Manual Clock[#] :  Adjust the image horizontal size

Manual Phase[#] :  Fine tune the data sampling position (adjust image quality)

Auto Source Seek :

- Auto : OFF ON : OFF / ON

ON – Auto source select always enable

OFF – Disable auto source select function

- Setup ▶ Selection for the corresponding input sources detection

VGA OFF ON

DVI OFF ON

HDMI OFF ON





HD/SD SDI 1⁺⁺ OFF ON

HD/SD SDI 2⁺⁺ OFF ON

Composite 1  OFF / ON
 Composite 2  OFF / ON
 S-Video 1  OFF / ON
 S-Video 2  OFF / ON
 Component 1  OFF / ON
 Component 2  OFF / ON

The corresponding input port name display on OSD menu will disappear once setting "OFF".



De-interlacing Mode* ▶

AFM  OFF / ON : Auto Film Mode
 TNR  OFF / ON : Temporal Noise Reduction
 MADi  OFF / ON : Motion Adaptive De-interlacing
 DCDi  OFF / ON : Low Angled De-interlacing
 [See Appendix VI for AFM, TNR, MADi, DCDi function description]

Auto Power :  OFF / ON
 ON – Enable soft power off function if absence of input signals
 OFF – Disable soft power function

Enable RGB SOG:  OFF / ON
 Video Standard (SD)* : Auto / NTSC / NTSC 4.43 / PAL / PAL M / SECAM
 Gamma : 0.6 / 0.7 / 0.8 / 1.0 / 1.6 / 1.8 / 1.9 / 2.0 / 2.1 / 2.2 / 2.3 / 2.4 / 2.5 / 2.6 / User Setting



OSD ▶

OSD position :
 H POS  : Move the OSD menu image horizontally
 V POS  : Move the OSD menu image vertically
 OSD Timeout (sec) : ON – 60 : Adjust the OSD menu timeout period in a step of 5 seconds (max 60 seconds)
 ON = Continuous to display OSD menu.
 60 = 60 seconds later will turn off the OSD menu.

Screen Marker ▶

Screen Marker : On/Off
 Center Marker : On/Off
 Safe Area Enable : On/ Off
 Aspect Marker Enable : On/Off
 Safe Area Market : 80%~99%
 Aspect Marker : 4:3 / 16:9
 Transparency Level : 0% / 25% / 50% / 75% / 100%
 Exit menu

Language : English / Spanish / French / German / Chinese :Select OSD menu language display

Transparency :  OFF / ON : Set OSD transparency
 Display Input :  OFF / ON : Display input source info after switching source.
 IR Remote Control : IR Enable / IR Disable : Enable or disable the IR function control.
 Real time clock ▶ show and edit the real time clock (This function is valid when "Display Input" sets ON.)

DATE : DD/MM/YYYY : Date/Month/Year
 TIME : HH/MM/SS (AM/PM): Hour/Minute/Second

SETUP ▶

Month / Day / Year
 Hour / Minute / AM/PM

Display Clock  OFF / ON : Disable or enable to display the real time clock when display video source info after switching source.

Freeze : Freeze the image (use "+" button)

Zoom ▶

Zoom level :  : Enable the zoom in function on the image displayed.
 Use "+" button to zoom in the image
 Use "-" button to decrease the zoomed image







Horizontal pan :  : Pan the image horizontally
 Vertical pan :  : Pan the image vertically

Factory Reset







Note : Freeze state will be cleared when you using zoom function.

Color Temperature ▶







5000K

Red Gain : 
 Green Gain : 
 Blue Gain : 
 Red Offset : 
 Green Offset : 
 Blue Offset : 
 Reset to Defaults : Resume to the default values







6500K

Red Gain : 
 Green Gain : 
 Blue Gain : 
 Red Offset : 
 Green Offset : 
 Blue Offset : 
 Reset to Defaults : Resume to the default values







8000K

Red Gain : 
 Green Gain : 
 Blue Gain : 
 Red Offset : 
 Green Offset : 
 Blue Offset : 
 Reset to Defaults : Resume to the default values

9300K

Red Gain : 
 Green Gain : 
 Blue Gain : 
 Red Offset : 
 Green Offset : 
 Blue Offset : 
 Reset to Defaults : Resume to the default values

User setting :



Red Gain : 
 Green Gain : 
 Blue Gain : 
 Red Offset : 
 Green Offset : 
 Blue Offset : 
 Reset to Defaults : Resume to the default values



Reset All to Defaults : Resume all color temperature settings to the default values.

Hot Key ▶
 Hot key 1 : Volume / Brightness / Contrast / Inputs / Aspect Ratio/ Zoom / Freeze / PIP Size / PIP Swap / Saturation / Hue / Backlight / Auto Picture Setup / Markers / No Function
 Hot key 2 : Volume / Brightness / Contrast / Inputs / Aspect Ratio / Zoom / Freeze / PIP Size / PIP Swap / Saturation / Hue / Backlight / Auto Picture Setup / Markers / No Function

Monochrome Mode ▶

- Color
- Red Monochrome
- Green Monochrome
- Blue Monochrome
- Red Only
- Green Only
- Blue Only

Backlight Setup ▶
 - B/L Invert :   : Invert for the backlight brightness

- B/L Control : D/A / PWM : Selection for voltage level dimming control / PWM dimming control
- Backlight Frequency :  100 ~ 440Hz in a step of 20
- Light Detector :  : Enable ambient light detector function by using KIT 70220-3

Default Setting ▶

- Reset to Factory Defaults ▶ (Activate when JC1 position 4 sets open)
Are you sure ? Yes/No
- Reset to Factory Defaults with (Color Temp.) ▶ (Activate when JC1 position 4 sets open)
Are you sure ? Yes/No
- Save Current Settings as Calibrated Values ▶ (Activate when JC1 position 2 sets closed)
Are you sure ? Yes/No
- Recall Stored Calibrated Values ▶
Are you sure ? Yes/No

* : DISPLAY IN VIDEO MODE ONLY
 # : DISPLAY IN ARGB MODE ONLY
 + FUNCTION DISABLE WHEN HD-3000 CONNECTED
 ++ DISPLAY WHEN HD-3000 CONNECTED

Firmware V0.39.00.00 or up

CONNECTORS, PINOUTS & JUMPERS

The various connectors are:

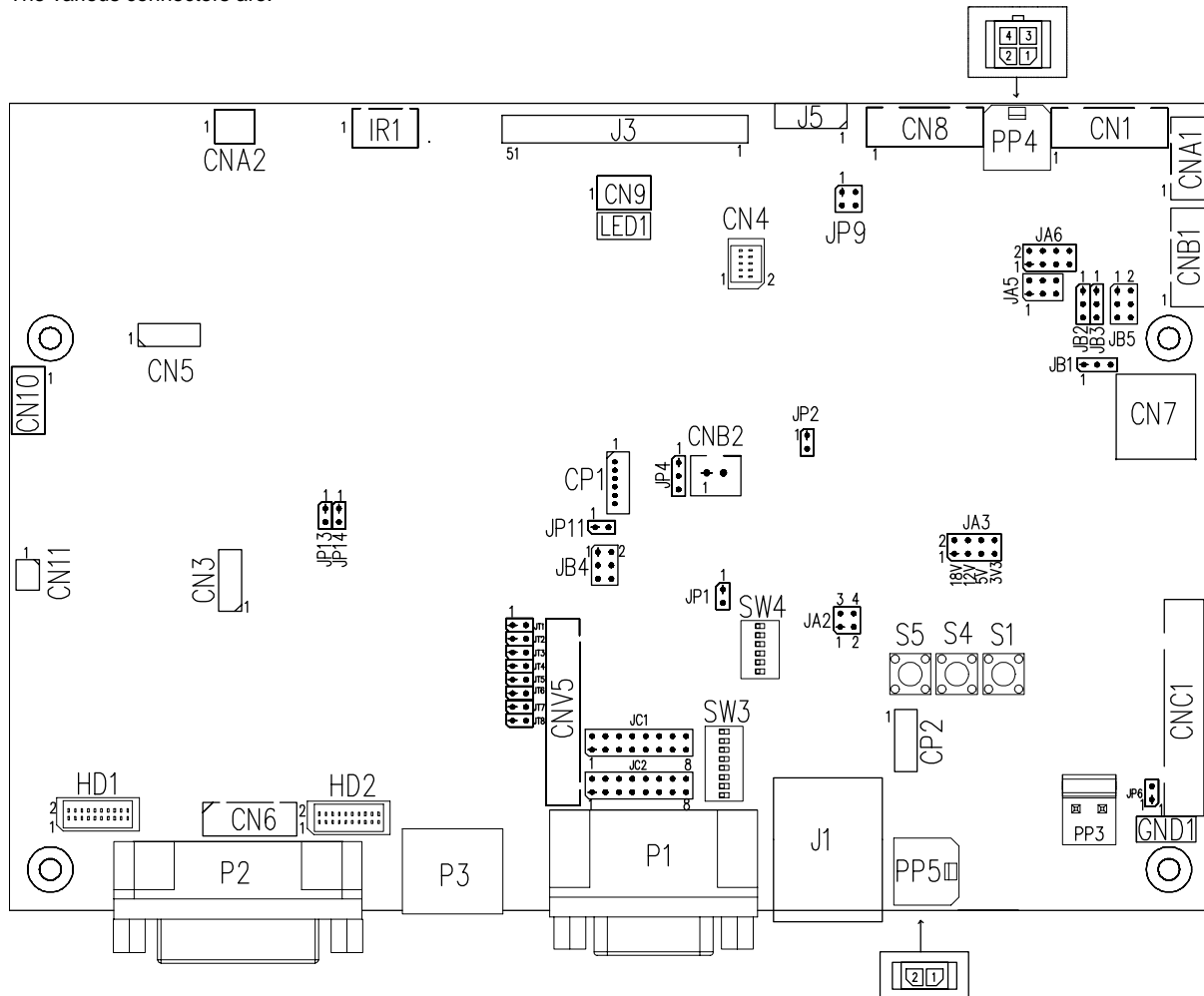

Summary: Connectors

| Ref | Purpose | Description |
|------|---|---|
| CN1 | Second RS-232 serial control | JST 6-way, B6B-XH-A (Matching type : XHP-6) |
| CN3 | Reserved for factory use | Reserved |
| CN4 | Panel control signal connector | Hirose 10-pin, DF20G-10DP-1V (Matching type : DF20A-10DS-1C) |
| CN5 | Reserved for factory use | Reserved |
| CN6 | No function | Reserved |
| CN7 | Audio board connector | DIL socket header 5x2 right angle (Matching audio Add-on Board P/N 416940020-3) |
| CN8 | RS-232 serial control | JST 6-way, B6B-XH-A (Matching type : XHP-6) |
| CN9 | Ambient light sensor connector | JST 3-way, B3B-PH-K (Matching type : PHR-3) |
| CN10 | HDMI audio (Stereo) output | JST 4 way, PHD-4 (Matching type : PHR-4) (Matching audio cable P/N 426451800-3 for connection to audio add-on board P/N 416940020-3 (connector : CN2)) |
| CN11 | SPDIF Audio output | JST B2B-ZR (Matching type : ZHR-2) (Matching extend cable P/N 426007400-3) |
| CP1 | Reserved for factory use | Reserved |
| CP2 | Reserved for factory use | Reserved |
| CNA1 | Auxiliary power output | JST 4-way, B4B-XH-A (Matching type : XHP-4) (Matching cable P/N 426040200-3) |
| CNA2 | Auxiliary +5VDC output | JST 2 way, B2B-PH-K (Matching type : PHR-2) |
| CNB1 | Backlight inverter | JST 5-way, B5B-XH-A (Matching type : XHP-5) (Matching cable P/N 426058300-3) |
| CNB2 | Backlight status input connector | JST 2 way, B2B-XH-A (Matching type : XHP-2) |
| CNC1 | OSD controls | JST 12-way, B12B-XH-A (Mating type : XHP-12) |
| CNV5 | Auxiliary video input | JST B26B-PHDSS, 26 ways (Matching video cable P/N 426301700-3) |
| HD1 | Auxiliary digital input connector – HD1 | JST BM20B-SRDS (Matching type : SHDR-20V-S-B) |
| HD2 | Auxiliary digital input connector – HD2 | JST BM20B-SRDS (Matching type : SHDR-20V-S-B) |



Specifications subject to change without notice

| | | |
|---------|---------------------------------|--|
| J1 | Ethernet for network connection | RJ45 connector |
| J3 | Panel signal for LVDS panel | JAE FI-RE51S-HF (Matching type : FI-RE51HL) |
| J5 | External panel power output | Molex 53261-0871 (Matching type : 51021-0800) |
| IR1 | Infra-Red sensor connector | JST 3-way, B3B-XH-A (Matching type : XHP-3) |
| LED1 | Dual color LED connector | Header pin 3x1 |
| P1 | VGA analog input | DB-15 way high density 3 row |
| P2 | DVI-D input | DVI-I connector |
| P3 | HDMI input | HDMI connector |
| PP2/PP3 | Power input (alternative) | DC power Molex 2 pin 0.156" pitch |
| PP4 | External panel power input | Molex 43045-0400 compatible (Matching connector type : Molex 43025-0400 compatible) (Matching power cable : P/N 426013700-3) |
| PP5 | Power input | Molex 43650-0200 compatible (Matching connector type : Molex 43645-0200 compatible) (Matching power cable : P/N 426013800-3) |
| SW3 | Panel selection | 8-way DIP Switch |
| SW4 | Function selection | 6-way DIP Switch |

Summary: Jumpers setting

| Ref | Purpose | Note |
|------|---|---|
| JA2 | On board +3.3V logic power enable | 1-2 & 3-4 closed, factory set, do not remove |
| JA3 | Panel power voltage select CAUTION: Incorrect setting can damage panel | See panel voltage setting table 1 |
| JA5 | Panel power voltage select CAUTION: Incorrect setting will cause panel damage | See panel voltage setting table 1 |
| JA6 | Panel power voltage select CAUTION: Incorrect setting will cause panel damage | See panel voltage setting table 1 |
| JB1 | Backlight brightness voltage range | 1-2 closed = 5V max 2-3 closed = 3.3V max |
| JB2 | Backlight inverter on/off control – signal level | 2-3 = On/Off control signal 'High' = +5V 1-2 = On/Off control signal 'High' = +3.3V Open = On/Off control signal 'High' = Open collector CAUTION: Incorrect setting can damage inverter. |
| JB3 | Backlight inverter on/off control – polarity | 1-2 = control signal 'high' = CCFT ON 2-3 = control signal 'low' = CCFT ON |
| JB4 | GPIO pins voltage selection | 1-2 = 3.3V 2-3 = 5V |
| JB5 | Backlight control type selection | 1-2 = VR/Digital switch mount control 3-4 = Analog backlight brightness - voltage range 0-5V 5-6 = PWM (Pulse Width Modulation) brightness |
| JC1 | Custom configuration | Position 2 : Closed = Enable save Current Settings as Calibrated Values on OSD menu Position 3 : Closed = Enable baud rate selection function in programming mode Position 4 : Closed = Hide "Reset to Factory Defaults" and "Reset to Factory Defaults with (Color Temp.)" from OSD menu. |
| JC2 | Custom configuration | Position 1 : Enable J3 – pin 5 (OP1) controlled by JB4 Position 2 : Enable J3 – pin 6 (OP2) controlled by JB4 Position 3 : Enable J3 – pin 21 (OP3) controlled by JB4 Position 4 : Enable J3 – pin 22 (OP4) controlled by JB4 |
| JP1 | Factory use | Default Open |
| JP2 | Factory use | Default Open |
| JP4 | Custom configuration | 1-2 closed = Reserved 3-4 closed = On-board programming 5-6 closed = Display "Blue only", "Green only", "Red only" function on OSD menu |
| JP6 | Input power control | Short = External switch control Open = Switch mount control |
| JP9 | Factory use | Default Open |
| JP13 | Factory use | Default Open |
| JP14 | Factory use | Default Open |
| JT1 | S-Video Chroma -in terminator enable | Open = S-video chroma input is not terminated Close = S-video chromainput is terminated with 75Ω |
| JT2 | S-Video luma-in terminator enable | Open = S-video luma input is not terminated Close = S-video luma input is terminated with 75Ω |
| JT3 | Composite video-in terminator enable | Open = composite input is not terminated Close = composite input is terminated with 75Ω |
| JT4 | Component luma-in terminator enable | Open = component luma input is not terminated Close = component luma input is terminated with 75Ω |
| JT5 | Component Cb/Pb-in terminator enable | Open = component Cb/Pb input is not terminated Close = component Cb/Pb input is terminated with 75Ω |
| JT6 | Component Cr/Pr-in terminator enable | Open = component Cr/Pr input is not terminated Close = component Cr/Pr input is terminated with 75Ω |
| JT7 | Composite video 2-in terminator enable | Open = composite video 2 input is not terminated Close = composite video 2 input is terminated with 75Ω |
| JT8 | Reserved | Reserved |
| S1 | Reserved | Reserved |
| S4 | Reserved | Reserved |
| S5 | Reserved | Reserved |
| SW3 | Panel & function selection | See table 2 |
| SW4 | Panel & function selection | See table 3 |

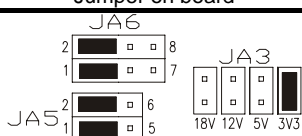
Table 1 : Panel voltage setting table :

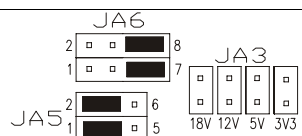

| Input voltage via PP2/PP3, PP5 | Panel Voltage | JA3 | JA5 | JA6 | Jumper on board |
|--------------------------------|---------------|------------|-----------|-----------|--|
| 12VDC | 3.3V | 3V3 closed | 1-3 & 2-4 | 1-3 & 2-4 |  |
| | 5V | 5V closed | 1-3 & 2-4 | 1-3 & 2-4 |  |
| | 12V | OPEN | 1-3 & 2-4 | 5-7 & 6-8 |  |

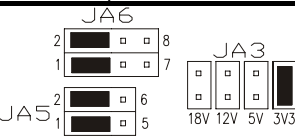
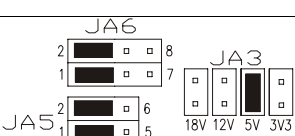
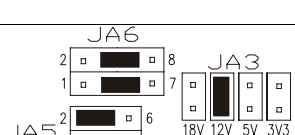
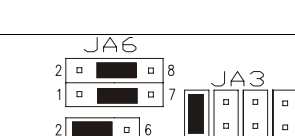
CAUTION: Incorrect setting can damage panel & controller

| Input voltage via PP2/PP3, PP5 | Panel Voltage | JA3 | JA5 | JA6 | Jumper on board |
|--------------------------------|---------------|------------|-----------|-----------|--|
| 24VDC** | 3.3V | 3V3 closed | 1-3 & 2-4 | 1-3 & 2-4 |  |
| | 5V | 5V closed | 1-3 & 2-4 | 1-3 & 2-4 |  |
| | 12V | 12V closed | 1-3 & 2-4 | 3-5 & 4-6 |  |
| | 18V | 18V closed | 1-3 & 2-4 | 3-5 & 4-6 |  |

CAUTION: Incorrect setting can damage panel & controller

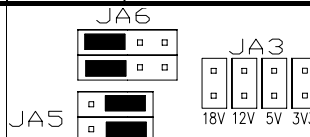
**** Ensure that the backlight inverter supports 24V operation prior to connecting a 24VDC input. Because CNA1 pin 1 and CNB1 pin 2 will output 24VDC if input 24VDC via PP2/PP3 or PP5.**

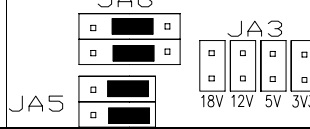
| Input voltage via PP4 | Panel Voltage | JA3 | JA5 | JA6 | Jumper on board |
|-----------------------|---------------|------|-----------|-----------|--|
| 3.3 / 5 / 12 / 18VDC* | 3.3V | OPEN | 3-5 & 4-6 | 1-3 & 2-4 |  |
| | 5V | OPEN | 3-5 & 4-6 | 1-3 & 2-4 |  |
| | 12V | OPEN | 3-5 & 4-6 | 3-5 & 4-6 |  |
| | 18V | OPEN | 3-5 & 4-6 | 3-5 & 4-6 |  |

* Maximum current for 3.3V, 5V = 7A, Maximum current for 12V = 5A, Maximum current for 18V = 3.5A

JA3, JA5 & JA6 location on board : (Please pay attention to the jumper settings on JA3, JA5 & JA6 which are red in color)

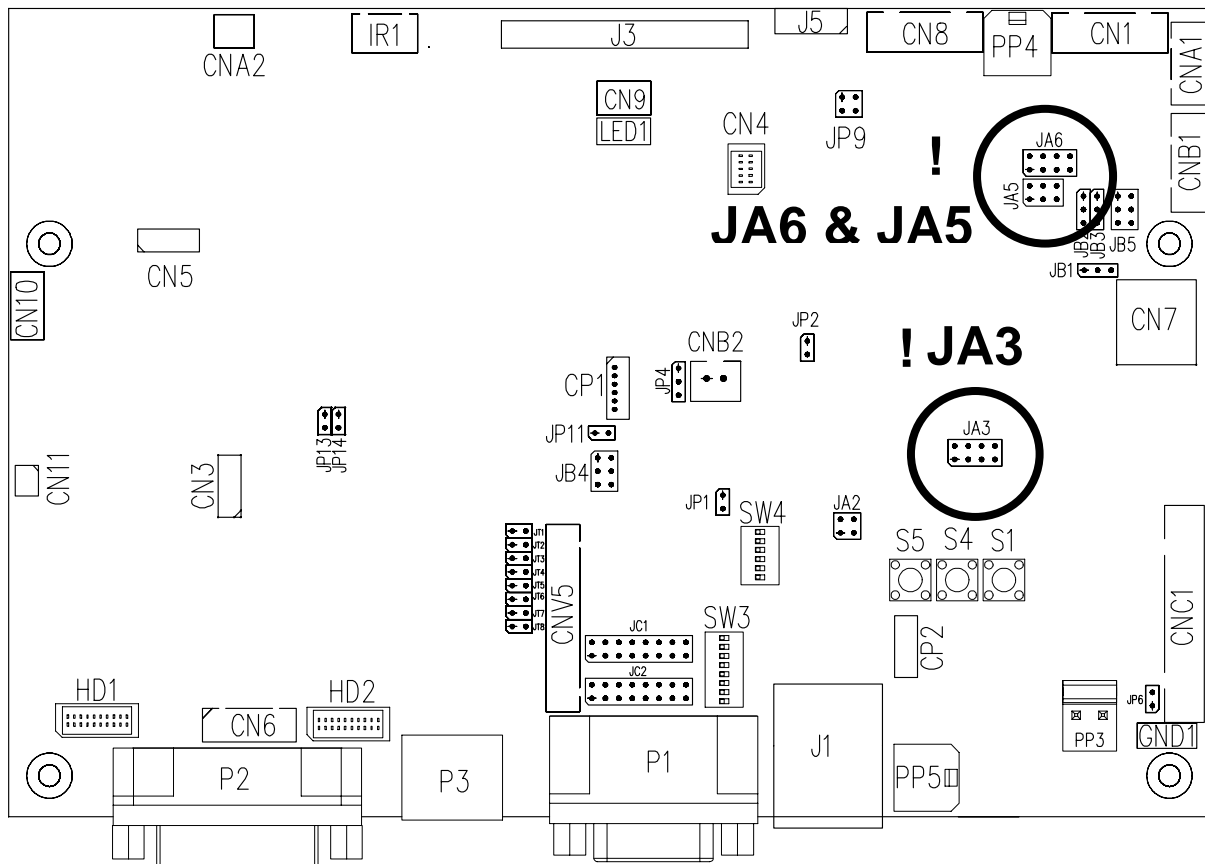

Table 2 : DIP Switch selection – SW3

| Pos #1 | Pos #2 | Pos #3 | Pos.#4 | Description | Panel resolution |
|-------------------------|--------|--------|--------|--|------------------|
| For WUXGA panels | | | | | |
| OFF | ON | ON | OFF | LG LM260WU1-SLB1 | 1920x1200 |
| ON | ON | ON | OFF | LG LM240WU2-SLA1 | 1920x1200 |
| OFF | OFF | OFF | OFF | Sharp LQ445D3LZ19 | 1920x1080 |
| ON | OFF | OFF | OFF | Samsung LTA460H2-L02 | 1920x1080 |
| OFF | ON | OFF | OFF | Sharp LQ170M1LZ04 | 1920x1200 |
| ON | ON | OFF | OFF | Samsung LTA700HH-LH1 (1 st trial testing) | 1920x1080 |
| OFF | OFF | ON | OFF | Samsung LTA700HH-LH1 (2 nd trial testing) | 1920x1080 |
| OFF | OFF | ON | ON | AU Optronics P645HW03 V0 (1920x1080) | 1920x1080 |
| OFF | OFF | ON | ON | AU Optronics P645HW03 V0 | 1920x1080 |
| For UXGA panels | | | | | |
| OFF | OFF | OFF | OFF | Fujitsu FLC59UXC8V-02A | 1600x1200 |
| ON | OFF | OFF | OFF | Samsung LTM213U6-L01 | 1600x1200 |
| For WXGA panels | | | | | |
| OFF | OFF | OFF | OFF | LG LC420W02-A4 | 1366x768 |
| ON | OFF | OFF | OFF | Sharp LQ315T3LZ24 | 1366x768 |
| ON | ON | OFF | OFF | Samsung LTA320W2-L01 / LTA230W1-L02 | 1366x768 |
| ON | ON | ON | ON | NEC NL12876BC26-21 / Samsung LTM170W1-L01 | 1280x768 |
| OFF | ON | ON | ON | CHI MEI N154I4-L01 | 1280x800 |
| OFF | OFF | ON | OFF | AU Optronics M190PW01 | 1440x900 |
| OFF | OFF | ON | ON | Sharp LQ072K1LA03 | 1280x768 |
| For SXGA panel | | | | | |
| OFF | OFF | OFF | OFF | Sharp LQ181E1LW31 | 1280x1024 |
| ON | OFF | OFF | OFF | AU Optronics M170EN05 | 1280x1024 |
| For XGA panel | | | | | |
| OFF | OFF | OFF | OFF | Sharp LQ150X1LGN2A | 1024x768 |
| | | | | Sharp LQ150X1LGB1 | 1024x768 |
| For SVGA panel | | | | | |
| OFF | OFF | OFF | OFF | Sharp LQ121S1DG11/41 | 800x600 |
| | | | | Toshiba LTM08C351 | 800x600 |
| For WVGA panel | | | | | |
| OFF | OFF | OFF | OFF | NEC NL8048BC24-01 | 800x480 |
| ON | OFF | OFF | OFF | Kyocera TCG085WV1AB-G00 | 800x480 |
| ON | OFF | ON | OFF | Sharp LQ070Y3LG4A | 800x480 |
| For VGA panel | | | | | |
| OFF | OFF | OFF | OFF | Sharp LQ104V1DG51 | 640x480 |
| ON | OFF | OFF | OFF | Sharp LQ104V1DG21 | 640x480 |
| ON | OFF | ON | OFF | Kyocera TCG075VG2AC-G00 | 640x480 |
| Others | | | | | |
| OFF | ON | OFF | OFF | AU Optronics M201EW02 V8 | 1680x1050 |
| OFF | OFF | ON | OFF | Samsung LTI430LA01 | 1920x480 |
| OFF | ON | ON | OFF | NEC NL10260BC19-01D | 1024x600 |
| ON | ON | ON | OFF | AU Optronics M200RW01 | 1600x900 |
| | | | | Samsung LTM200KP01 | 1600x900 |

Remark : The above panel timings are copy the panel data direct from SVX-1920. Some of the panel timings settings may not exactly to match the panel model we specified in this table.

| Pos #5 | Pos #6 | Pos #7 | Description |
|--------|--------|--------|---------------|
| OFF | OFF | OFF | WUXGA |
| ON | OFF | OFF | UXGA |
| OFF | ON | OFF | SXGA |
| ON | ON | OFF | WXGA |
| OFF | OFF | ON | XGA |
| ON | OFF | ON | SVGA |
| OFF | ON | ON | VGA |
| ON | ON | ON | WVGA / Others |

| | | |
|---------|------------|--|
| Pos. #8 | Video lock | ON – Disable : The output refresh rate locks to the input for 50Hz / 60Hz mode (other resolution lock the output be 60Hz.) OFF – Enable : Always fix the output be 60Hz. |
|---------|------------|--|

Table 3 : DIP switch selection – SW4

| Pos. # | Function | Description |
|--------|--|--|
| 1 | Reserved | |
| 2 | Panel pixel format | OFF : Double Pixel ON : Single Pixel |
| 3 | Panel selection | ON : LVDS panel OFF : Reserved |
| 4 | LVDS data mapping select (Refer to Table 2) | If SW4 position 5 = OFF (8 bit) OFF : Mapping B ON : Mapping A Please adjust to get the correct picture. See as Appendix I for details of mapping of A and B. If SW4 position 5 = ON (10 bit) OFF : JEIDA (LVDS panel) ON : VESA (LVDS panel) Please adjust to get the correct picture. See as Appendix I for details of mapping of VESA and JEIDA. |
| 5 | Output LVDS display mode selection | OFF : 8 bit ON : 10 bit |
| 6 | Reserved | |

CN1 – Slave RS-232 serial control: JST B6B-XH-A (Matching type : XHP-6)

| PIN | SYMBOL | DESCRIPTION |
|-----|--------|----------------|
| 1 | SDATA | Reserved |
| 2 | SCLK | Reserved |
| 3 | VCC | +5V |
| 4 | TXD | RS-232 Tx data |
| 5 | GND | Ground |
| 6 | RXD | RS-232 Rx data |

CN4 – Panel connector: HIROSE DF20G-10DP-1V (Matching type : DF20A-10DS-1C)

| PIN | SYMBOL | DESCRIPTION |
|-----|---------------|-------------|
| 1 | OP1 | Reserved |
| 2 | OP2 | Reserved |
| 3 | OP3 | Reserved |
| 4 | OP4 | Reserved |
| 5 | IP1 | Reserved |
| 6 | IP2 | Reserved |
| 7 | IP3 | Reserved |
| 8 | IP4 | Reserved |
| 9 | EXT_MSTR2_SDA | Reserved |
| 10 | EXT_MSTR2_SCL | Reserved |

CN7 - Audio connector: DIL socket header 5x2 right angle [OPERATE UNDER 12VDC POWER INPUT ENVIRONMENT]

| PIN | SYMBOL | DESCRIPTION |
|-----|-----------|-------------------------------------|
| 1 | VCC | Audio board logic power supply, +5V |
| 2 | VOLSEL0 | Reserved |
| 3 | VOLSEL1 | Reversed |
| 4 | TUNAUSEL | Reserved |
| 5 | CLK/CNT | Reserved |
| 6 | GND | Ground |
| 7 | +12V/+24V | Audio board power supply, +12V/+24V |
| 8 | NC | No connection |
| 9 | NC | No connection |
| 10 | GND | Ground |

CN8 – RS-232 serial control: JST B6B-XH-A (Matching type : XHP-6)

| PIN | SYMBOL | DESCRIPTION |
|-----|--------|----------------|
| 1 | SDATA | Reserved |
| 2 | SCLK | Reserved |
| 3 | VCC | +5V |
| 4 | TXD | RS-232 Tx data |
| 5 | GND | Ground |
| 6 | RXD | RS-232 Rx data |

CN9 – Ambient light sensor connector : JST B3B-PH-K (Matching type : PHR-3)

| PIN | SYMBOL | DESCRIPTION |
|-----|--------|--------------------------------|
| 1 | GND | Ground |
| 2 | VCC_5V | VCC 5V |
| 3 | ALSF | Ambient light sensing feedback |

CN10 - HDMI Audio out (Matching type : XHP-4)

| PIN | SYMBOL | DESCRIPTION |
|-----|------------|----------------|
| 1 | GND | GND |
| 2 | AUDIO LOUT | HDMI LEFT OUT |
| 3 | GND | GND |
| 4 | AUDIO ROUT | HDMI RIGHT OUT |

CN11 – SPDIF audio output connector : JST B3B-PH-K (Matching type : PHR-3)

| PIN | SYMBOL | DESCRIPTION |
|-----|--------|----------------------------|
| 1 | SPDIF | SPDIF Digital audio output |
| 2 | GND | Ground |

CNA1 - Auxiliary power output: JST B4B-XH-A (Matching type : XHP-4)

| PIN | SYMBOL | DESCRIPTION |
|-----|---------------|---------------------------|
| 1 | AUX 12V / 24V | +12V / +24V DC, 500mA max |
| 2 | GND | Ground |
| 3 | GND | Ground |
| 4 | AUX 5V | +5V DC, 500mA max |

CNA2 - Auxiliary power output: JST B2B-PH-K (Matching type : PHR-2)

| PIN | SYMBOL | DESCRIPTION |
|-----|--------|-----------------------------|
| 1 | Vcc_5V | +5V DC, 500mA max with fuse |
| 2 | GND | Ground |

CNB1 – Backlight inverter connector: JST B5B-XH-A (Matching type : XHP-5)

| PIN | SYMBOL | DESCRIPTION |
|-----|---------|---|
| 1 | GND | Ground |
| 2 | VBKL | +12V / +24V DC, backlight power supply |
| 3 | BLCTRL | On/Off control (enable) – see JB2 & JB3 |
| 4 | BVR_WIP | Brightness VR – WIP |
| 5 | BVR_A | Brightness VR A |

CNB2 – Backlight status input inverter connector: JST B2B-XH-A (Matching type : XHP-2)

| PIN | SYMBOL | DESCRIPTION |
|-----|-----------|----------------------------------|
| 1 | BL_STATUS | Backlight status (Normal = High) |
| 2 | GND | Ground |

CNC1 – Function controls connector: JST B12B-XH-A (Matching type : XHP-12)

| PIN | SYMBOL | DESCRIPTION |
|-----|----------|--|
| 1 | PSWIN | Power switch A |
| 2 | SW_ON | Power switch B |
| 3 | BVR_A | Backlight brightness VR pin A |
| 4 | BVR_WIP | Backlight brightness VR pin WIP |
| 5 | BVR_B | Backlight brightness VR pin B (470Ω resistor to +5V Vcc) |
| 6 | GND | Ground |
| 7 | MENU | OSD menu button |
| 8 | -/LEFT | OSD -/Left button |
| 9 | + /RIGHT | OSD +/Right button |
| 10 | SEL_DN | OSD Select down button |
| 11 | SEL_UP | OSD Select up button |
| 12 | NC | No connection |

The VR for brightness depends on the inverter. The main power load for On/Off is handled by a relay on the controller.

CNV5 – Auxiliary Video input connector, JST B26B-PHDSS, 26 ways (Matching video cable P/N 426301700-3)

| PIN | DESCRIPTION |
|-----|-----------------------|
| 1 | S-Video 1 : Chroma in |
| 2 | Ground |
| 3 | S-Video 1 : Luma in |
| 4 | Ground |
| 5 | Composite video 1 in |
| 6 | Ground |
| 7 | Y in_1 |
| 8 | Ground |
| 9 | Cb/Pb in_1 |
| 10 | Ground |
| 11 | Cr/Pr in_1 |
| 12 | Ground |
| 13 | S-Video 2 : Chroma in |
| 14 | Ground |
| 15 | S-Video 2 : Luma in |
| 16 | Ground |
| 17 | Composite video in 2 |
| 18 | Ground |
| 19 | Cr/Pr in_2 |
| 20 | Ground |
| 21 | Y in_2 |
| 22 | Ground |
| 23 | Cb/Pb in_2 |
| 24 | Ground |
| 25 | Reserved |
| 26 | Ground |

HD1 – Auxiliary Digital input connector – HD1 : JST BM20B-SRDS (Matching type : SHDR-20V-S-B)

| PIN | SYMBOL | DESCRIPTION |
|-----|--------|----------------|
| 1 | GND | Digital Ground |
| 2 | GND | Digital Ground |
| 3 | RXC | TMDS Clock+ |
| 4 | /RXC | TMDS Clock- |
| 5 | RX0 | TMDS Data 0+ |

| | | |
|----|---------------|-------------------------------------|
| 6 | /RX0 | TMDS Data 0- |
| 7 | RX1 | TMDS Data 1+ |
| 8 | /RX1 | TMDS Data 1- |
| 9 | RX2 | TMDS Data 2+ |
| 10 | /RX2 | TMDS Data 2- |
| 11 | GND | Ground (+5, Analog H/V Sync) |
| 12 | GND | Digital Ground |
| 13 | EXT_MSTR2_SCL | Reserved |
| 14 | EXT_MSTR2_SDA | Reserved |
| 15 | DDC_5V | +5V power supply for DDC (optional) |
| 16 | HPD | Hot plug detect |
| 17 | IN_SEC1_SCL | DDC Clock |
| 18 | IN_SEC1_SDA | DDC Data |
| 19 | VCC | Analog horizontal sync |
| 20 | VCC | Ground |

HD2 – Auxiliary Digital Input connector – HD2 : JST BM20B-SRDS (Matching type : SHDR-20V-S-B)

| PIN | SYMBOL | DESCRIPTION |
|-----|---------------|-------------------------------------|
| 1 | GND | Digital Ground |
| 2 | GND | Digital Ground |
| 3 | RXC | TMDS Clock+ |
| 4 | /RXC | TMDS Clock- |
| 5 | RX0 | TMDS Data 0+ |
| 6 | /RX0 | TMDS Data 0- |
| 7 | RX1 | TMDS Data 1+ |
| 8 | /RX1 | TMDS Data 1- |
| 9 | RX2 | TMDS Data 2+ |
| 10 | /RX2 | TMDS Data 2- |
| 11 | GND | Ground (+5, Analog H/V Sync) |
| 12 | GND | Digital Ground |
| 13 | EXT_MSTR2_SCL | Reserved |
| 14 | EXT_MSTR2_SDA | Reserved |
| 15 | DDC_5V | +5V power supply for DDC (optional) |
| 16 | HPD | Hot plug detect |
| 17 | IN_SEC1_SCL | DDC Clock |
| 18 | IN_SEC1_SDA | DDC Data |
| 19 | VCC | Analog horizontal sync |
| 20 | VCC | Ground |

IR1 – Infra-Red sensor connector: JST B3B-XH-A (Matching type : XHP-3)

| PIN | SYMBOL | DESCRIPTION |
|-----|-----------|------------------|
| 1 | GND | Ground |
| 2 | STDBY_Vcc | Stand by voltage |
| 3 | IR Data | IR data |

J3 – LVDS output connector: JAE FI-RE51S-HF (Matching type : JAE FI-RE51HL)

| PIN | SYMBOL | DESCRIPTION |
|-----|---------------|---|
| 1 | VDD (+12/18V) | Panel power supply (+12/18V) (selected by JA3, JA5 & JA6) |
| 2 | VDD (+12/18V) | Panel power supply (+12/18V) (selected by JA3, JA5 & JA6) |
| 3 | VDD (+12/18V) | Panel power supply (+12/18V) (selected by JA3, JA5 & JA6) |
| 4 | VDD (+12/18V) | Panel power supply (+12/18V) (selected by JA3, JA5 & JA6) |
| 5 | VDD (+12/18V) | Panel power supply (+12/18V) (selected by JA3, JA5 & JA6) |
| 6 | VDD (3,3V/5V) | Panel power supply (3,3V/5V) (selected by JA3, JA5 & JA6) |
| 7 | VDD (3,3V/5V) | Panel power supply (3,3V/5V) (selected by JA3, JA5 & JA6) |
| 8 | VDD (3,3V/5V) | Panel power supply (3,3V/5V) (selected by JA3, JA5 & JA6) |
| 9 | VDD (3,3V/5V) | Panel power supply (3,3V/5V) (selected by JA3, JA5 & JA6) |
| 10 | VDD (3,3V/5V) | Panel power supply (3,3V/5V) (selected by JA3, JA5 & JA6) |
| 11 | GND | Ground |
| 12 | GND | Ground |
| 13 | GND | Ground |
| 14 | GND | Ground |
| 15 | GND | Ground |
| 16 | OP1 | - |
| 17 | OP2 | - |
| 18 | OP3 | - |
| 19 | OP4 | - |
| 20 | GND | Ground |
| 21 | GND | Ground |
| 22 | TXA4+ | Positive differential LVDS data bit A4 |
| 23 | TXA4- | Negative differential LVDS data bit A4 |

Specifications subject to change without notice

| | | |
|----|-------|--|
| 24 | TXA3+ | Positive differential LVDS data bit A3 |
| 25 | TXA3- | Negative differential LVDS data bit A3 |
| 26 | GND | Ground |
| 27 | TXAC+ | Positive LVDS clock for A channel |
| 28 | TXAC- | Negative LVDS clock for A channel |
| 29 | GND | Ground |
| 30 | TXA2+ | Positive differential LVDS data bit A2 |
| 31 | TXA2- | Negative differential LVDS data bit A2 |
| 32 | TXA1+ | Positive differential LVDS data bit A1 |
| 33 | TXA1- | Negative differential LVDS data bit A1 |
| 34 | TXA0+ | Positive differential LVDS data bit A0 |
| 35 | TXA0- | Negative differential LVDS data bit A0 |
| 36 | GND | Ground |
| 37 | TXB4+ | Positive differential LVDS data bit B4 |
| 38 | TXB4- | Negative differential LVDS data bit B4 |
| 39 | TXB3+ | Positive differential LVDS data bit B3 |
| 40 | TXB3- | Negative differential LVDS data bit B3 |
| 41 | GND | Ground |
| 42 | TXBC+ | Positive LVDS clock for B channel |
| 43 | TXBC- | Negative LVDS clock for B channel |
| 44 | GND | Ground |
| 45 | TXB2+ | Positive differential LVDS data bit B2 |
| 46 | TXB2- | Negative differential LVDS data bit B2 |
| 47 | TXB1+ | Positive differential LVDS data bit B1 |
| 48 | TXB1- | Negative differential LVDS data bit B1 |
| 49 | TXB0+ | Positive differential LVDS data bit B0 |
| 50 | TXB0- | Negative differential LVDS data bit B0 |
| 51 | GND | Ground |

J5 – LVDS Panel connector: Molex 53261--0871, (Matching type : 51021-0800)

| PIN | SYMBOL | DESCRIPTION |
|-----|---------------|------------------------------|
| 1 | VDD (3,3V/5V) | Panel power supply (3,3V/5V) |
| 2 | VDD (3,3V/5V) | Panel power supply (3,3V/5V) |
| 3 | GND | Ground |
| 4 | GND | Ground |
| 5 | GND | Ground |
| 6 | VDD (12V/18V) | Panel power supply (12V/18V) |
| 7 | VDD (12V/18V) | Panel power supply (12V/18V) |
| 8 | VDD (12V/18V) | Panel power supply (12V/18V) |

LED1 – Status LED connector: 3-pin header

| PIN | DESCRIPTION |
|-----|--------------------------|
| 1 | Green LED pin (anode) |
| 2 | LED pin common (cathode) |
| 3 | Red LED pin (anode) |

P1 - Analog VGA in - 15 way connector

| PIN | SYMBOL | DESCRIPTION |
|-----|---------|--|
| 1 | PCR | Red, analog |
| 2 | PCG | Green, analog |
| 3 | PCB | Blue analog |
| 4 | ID2 | Reserved for monitor ID bit 2 (grounded) |
| 5 | DGND | Digital ground |
| 6 | AGND | Analog ground red |
| 7 | AGND | Analog ground green |
| 8 | AGND | Analog ground blue |
| 9 | DDC_5V | +5V power supply for DDC (optional) |
| 10 | DGND | Digital ground |
| 11 | ID0 | Reserved for monitor ID bit 0 (grounded) |
| 12 | DDC_SDA | DDC serial data |
| 13 | HS_IN | Horizontal sync or composite sync, input |
| 14 | VS_IN | Vertical sync, input |
| 15 | DDC_SCL | DDC serial clock |

P2 – DVI-D in

| PIN | SYMBOL | DESCRIPTION |
|-----|--------|----------------|
| 1 | /RX2 | TMDS Data 2- |
| 2 | RX2 | TMDS Data 2+ |
| 3 | GND | Digital Ground |
| 4 | NC | No connection |

Specifications subject to change without notice

| | | |
|----|---------|-------------------------------------|
| 5 | NC | No connection |
| 6 | DDC_CLK | DDC Clock |
| 7 | DDC_DAT | DDC Data |
| 8 | NC | No connection |
| 9 | /RX1 | TMDS Data 1- |
| 10 | RX1 | TMDS Data 1+ |
| 11 | GND | Digital Ground |
| 12 | NC | No connection |
| 13 | NC | No connection |
| 14 | DDC_5V | +5V power supply for DDC (optional) |
| 15 | GND | Ground (+5, Analog H/V Sync) |
| 16 | NC | No connection |
| 17 | /RX0 | TMDS Data 0- |
| 18 | RX0 | TMDS Data 0+ |
| 19 | GND | Digital Ground |
| 20 | NC | No connection |
| 21 | NC | No connection |
| 22 | GND | Digital Ground |
| 23 | RXC | TMDS Clock+ |
| 24 | /RXC | TMDS Clock- |
| C1 | NC | No connection |
| C2 | NC | No connection |
| C3 | NC | No connection |
| C4 | HS_IN | Analog horizontal sync |
| C5 | GND | Ground |
| C6 | NC | No connection |

PP2/PP3 – Alternate 12V/24VDC power supply

| PIN | DESCRIPTION |
|-----|-------------------|
| 1 | +12VDC / 24VDC in |
| 2 | Ground |

PP4 – External panel power input

| PIN | DESCRIPTION |
|-----|----------------------|
| 1 | External panel power |
| 2 | Ground |
| 3 | External panel power |
| 4 | Ground |

PP5 - 12VDC power supply

| PIN | DESCRIPTION |
|-----|---------------|
| 1 | +12V / +24VDC |
| 2 | Ground |

CONTROLLER DIMENSIONS

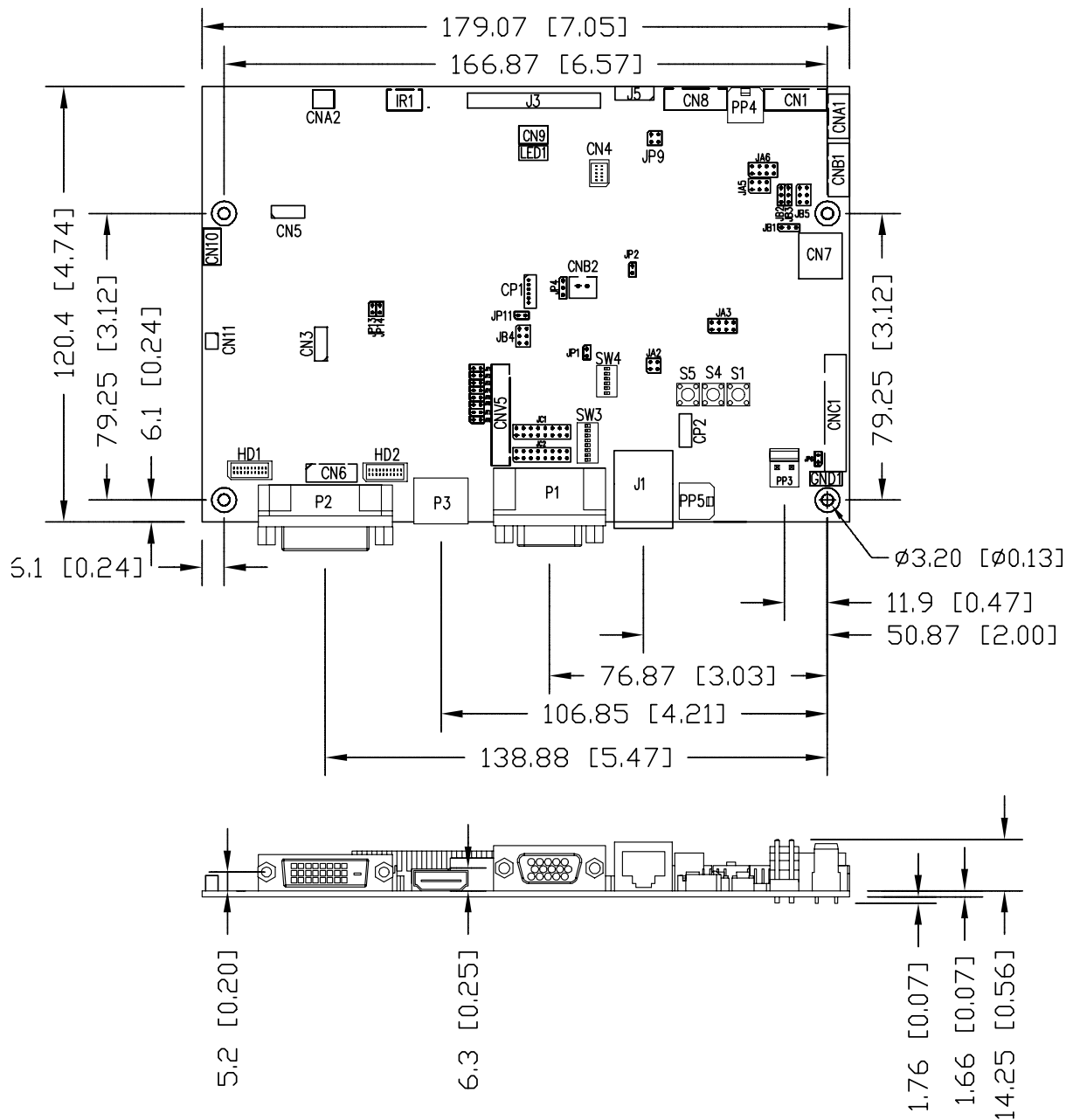

Ready-made 3D Pro-E (SLDPRT) drawing files - Save time and effort for your system volumetric analysis design. Includes jpg file previews. Please go to download at <http://www.digitalview.com/products/sgx-1920-lcd-controller>

The maximum thickness of the controller is 17.67mm with or without video add-on board (measured from bottom of PCB to top of components, including any underside components & leads). We recommend clearances of:

- 5mm from bottom of PCB - if mounting on a metal plate we also recommend a layer of suitable insulation material is added to the mounting plate surface.
- 10mm above the components
- 3-5mm around the edges

Any of the holes shown above can be used for mounting the PCB, they are 3.2mm in diameter.

CAUTION: Ensure adequate insulation is provided for all areas of the PCB with special attention to high voltage parts such as the inverter.

APPLICATION NOTES

USING THE CONTROLLER WITHOUT BUTTONS ATTACHED

This is very straightforward:

- Firstly setup the controller/display system with the buttons. With controls attached and display system active make any settings for colour, tint and image position as required then switch everything off.
- Remove the control switches, the 12-way (CNC1) cable.
- Use a jumper or similar to connect pins 1 & 2 on CNC1, this will fix the board On.
- Refer to inverter specifications for details as to fixing brightness to a desired level, this may require a resistor, an open circuit or closed circuit depending on inverter.

Summary: On CNC1 the only pins that are used are for On/Off and Brightness (if controller mounted inverter is used). On CNC1 the pins are for momentary type buttons so it doesn't matter that no buttons are attached.

INVERTER CONNECTION

There are potentially 3 issues to consider with inverter connection:

- Power
- Enable
- Brightness

Please read the following sections for a guide to these issues.

Inverter Power: As per the table for CNB1 pin 1 is ground and pin 2 provides 12V/24V DC. This should be matched with the inverter specification: see table.

CNB1

| PIN | DESCRIPTION |
|-----|-------------|
| 1 | Ground |
| 2 | +12V/+24VDC |

Remark: For higher power inverter, more current (for 12V/24V) can be taken from CNA1 pin 1.

Enable: This is a pin provided on some inverters for On/Off function and is used by this panel controller for VESA DPMS compliance. If the inverter does not have an enable pin or the enable pin is not used then DPMS will not be operational. Pin 3 should be matched to the inverters specification for the 'enable' or 'disable' pin.

CNB1

| PIN | DESCRIPTION |
|-----|-------------|
| 3 | Enable |

Further, jumpers JB2 & JB3 should be set to match the inverters specification for the enable pin power and High or Low setting: see table.

| Ref | Purpose | Note |
|-----|-------------------------|--|
| JB2 | Inverter enable voltage | 1-2 H = 12V/24V, 2-3 H = 5V (Vcc), OPEN H = open collector |
| JB3 | Inverter control | 1-2 H = On, 2-3 L = On |

Brightness: There are various methods for brightness control and it is important to consider the specifications for the inverter to be used. Generally the situation is:

- Brightness can control by using a resistor or VR (Variable Resistor).
- Brightness controlled by adding a circuit such as PWM (Pulse Width Modulation).
- No adjustment of brightness is possible.

CNB1 pins 4 & 5 are available for connecting to an inverter or circuit where VR control is supported.

CNB1

| PIN | DESCRIPTION |
|-----|-------------|
| 4 | VR WIP |
| 5 | VR A |

This can then be matched with function controls connected to CNC1 pins 4 & 3 or 5: see table.

CNC1

| PIN | DESCRIPTION |
|-----|-------------|
| 3 | VR A |
| 4 | VR WIP |
| 5 | VR B |

Design Guideline for making VR circuitry :

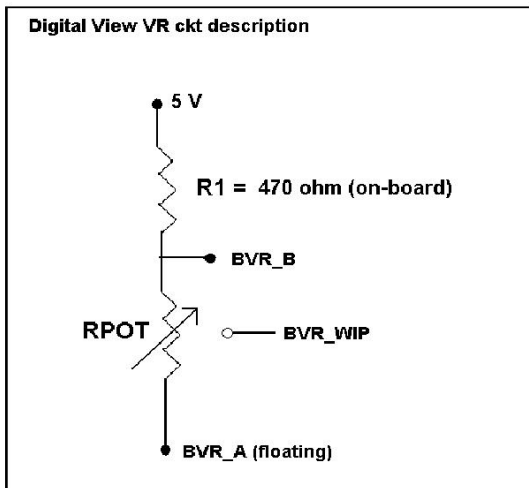

Signal description / Notes :

- 1) R1 : 470ohm on board
- 2) RPOT is an external potentiometer (in-line dip style) that can be plugged directly into CNC1 pins 3,4,5. RPOT must be supplied / installed by user.
- 3) BVR_B : Voltage tapped from “top” of potentiometer, the node of R1 and RPOT.
- 4) BVR_WIP : Voltage tapped from wiper arm of RPOT.
- 5) BVR_A : Voltage tapped from “bottom” of RPOT.

Note : BVR_A voltage is left floating on the controller board. To use this circuit, you need to tie this point to a potential (usually GND, available at CNC1 pin 6).

CNB1 – Backlight inverter connector: JST B5B-XH-A (Matching type : XHP-5)

| PIN | SYMBOL | DESCRIPTION |
|-----|---------|---|
| 1 | GND | Ground |
| 2 | VBKL | +12V/24VDC, backlight power supply |
| 3 | BLCTRL | On/Off control (enable) – see JB2 & JB3 |
| 4 | BVR_WIP | Brightness VR - WIP |
| 5 | BVR_A | Brightness VR A |

CNC1 – Control switch, JST B12B-XH-A (Matching type : XHP-12)

| PIN | SYMBOL | DESCRIPTION |
|-----|----------|---|
| 1 | PSWIN | Power button A |
| 2 | SW_ON | Power button B |
| 3 | BVR_A | Backlight Brightness VR pin A |
| 4 | BVR_WIP | Backlight Brightness R pin WIP |
| 5 | BVR_B | Backlight Brightness VR pin B (470 ohm resistor to +5V Vcc) |
| 6 | GND | Ground |
| 7 | MENU | OSD menu |
| 8 | -/LEFT | OSD -/Left |
| 9 | + /RIGHT | OSD +/Right |
| 10 | SEL_DN | OSD Select down |
| 11 | SEL_UP | OSD Select up |
| 12 | NC | No connection |

The VR for brightness depends on the inverter. The main power load for On/Off is handled by a relay on the controller.

Example for circuit design :

- 1.) Choose RPOT = 10K
- 2.) Tie BVR_A to GND
- 3.) Circuit analysis gives BVR_WIP as the following (see Figure 1)

$$BVR_WIP = 5 \times (Rbc/10.47)$$

where BVR_WIP is in Volts.
And Rbc is the resistance from the wiper arm to bottom of pot in Kohms.

To evaluate, plug in different values of Rbc :

| Rbc | BVR_WIP |
|-------|---------|
| 0 | 0 V |
| 2.5 K | 1.2 V |
| 5 K | 2.4 V |
| 7.5 K | 3.6 V |
| 10 K | 4.8 V |

So this circuit could provide Brightness adjust voltage ranging from 0V to 5V.

Specifications subject to change without notice

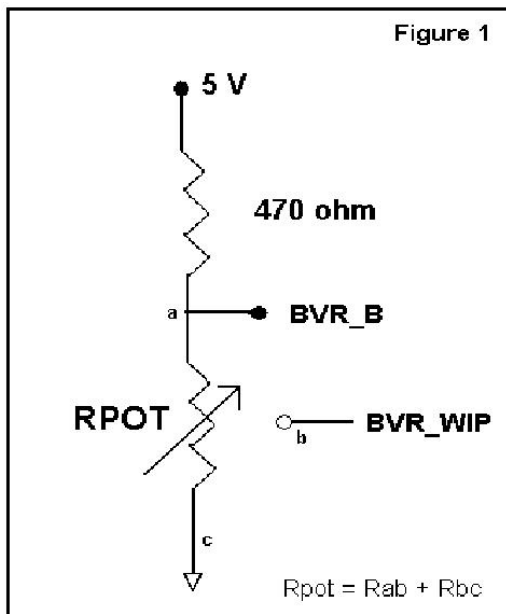

TROUBLESHOOTING

General

A general guide to troubleshooting a flat panel display system it is worth considering the system as separate elements, such as:

- Controller (jumpers, PC settings)
- Panel (controller, cabling, connection, panel, PC settings)
- Backlight (inverter, cabling, backlight tubes)
- Cabling
- Computer system (display settings, operating system)

Through step by step cross checking with instruction manuals and a process of elimination to isolate the problem it is usually possible to clearly identify the problem area.

No image:

- If the panel backlight is not working it may still be possible to just see some image on the display.
- A lack of image is most likely to be caused by incorrect connection, lack of power, failure to provide a signal or incorrect graphic card settings.

Image position:

If it is impossible to position the image correctly, i.e. the image adjustment controls will not move the image far enough, then test using another graphics card. This situation can occur with a custom graphics card that is not close to standard timings or if something is in the graphics line that may be affecting the signal such as a signal splitter (please note that normally a signal splitter will not have any adverse effect).

Image appearance:

- A faulty panel can have blank lines, failed sections, flickering or flashing display
- Incorrect graphics card refresh rate, resolution or interlaced mode will probably cause the image to be the wrong size, to scroll, flicker badly or possibly even no image.
- Incorrect jumper settings on the controller may cause everything from total failure to incorrect image. CAUTION: Do not set the panel power input incorrectly.
- Sparkling on the display: faulty panel signal cable.

Backlight:

Items to check include: Power input, Controls, Inverter and Tubes generally in this order.

If half the screen is dimmer than the other half:

- Check cabling for the inverter.
- For a specific backlight tube check the AC pins orientation (CAUTION: Never reverse any DC power pins).

Also:

- If adjusting brightness control has no effect the chances are that the VR rating or method of adjusting brightness is not compatible or correctly connected to the inverter.
- If system does not power down when there is a loss of signal

Continued failure:

If unit after unit keeps failing consider and investigate whether you are short circuiting the equipment or doing something else seriously wrong.

Generally after common sense issues have been resolved we recommend step by step substitution of known working parts to isolate the problem.

SPECIFICATIONS

| | |
|---------------------------------------|--|
| Panel compatibility | Compatible with 1920x1200, 1920x1080, 1920x480, 1680x1050, 1600x1200, 1600x900, 1440x900, 1366x768, 1280x1024, 1280x800, 1280x768, 1024x768, 1024x600, 800x600, 800x480 and 640x480 resolutions of TFT LCD panels. A specified BIOS and some factory adjustment may be required for individual panel timings. |
| No. of colours | Up to 3 x 10 bit providing 1.06 billion colours. |
| Panel power | DC 3.3V, 5V, 12V, 18V |
| Panel signal | LVDS |
| Vertical refresh rate | 60Hz at 1920x1200, 60Hz at 1920x1080, 60Hz at UXGA and up to 75Hz other lower resolution |
| Display clock maximum | 165MHz |
| ADC clock maximum | 195 MHz |
| DVI differential input clock maximum | 165MHz |
| Graphics formats | Standard VESA VGA, SVGA, XGA, SXGA, WXGA, UXGA, WUXGA Other special formats through specified BIOS and factory adjustment. |
| Graphics auto mode detect | VGA, SVGA, XGA, SXGA, WXGA, UXGA & WUXGA interlaced and non-interlaced |
| Standard input at source (analog RGB) | VGA analog (15 pin) standard with automatic detection of: Digital Separate Sync; Composite Sync Sync On Green. |
| Video formats | PAL, NTSC & SECAM |
| Video inputs | ARGB DVI-D Composite video 1 Composite video 2 S-Video 1 S-Video 2 Component video 1 Component video 2 HD-SDI 1 (with optional adaptor board) HD-SDI 2 (with optional adaptor board) HDMI |
| Functions display | On screen display (OSD) of functions |
| OSD menu functions | Image controls: Panel brightness/contrast, Saturation, Hue, Color temperature, Sharpness, Video Scaling, PIP, OSD position, OSD timeout, Image orientation, Auto Source Seek, etc. |
| OSD menu controls available | Power On/Off Backlight brightness OSD Menu OSD Select up OSD Select down Setting + Setting - |
| Control interface | Buttons, RS-232, Remote control |
| Settings memory | Settings are stored in non volatile memory |
| PC Connectivity | VGA / SVGA / XGA / SXGA / UXGA / WUXGA analog or digital |
| Controller dimensions | 179mm x 120.4mm (7." x 4.74") |
| Power consumption | 10w approx. (not including panel power consumption) |
| Power load maximum | The controller has an overall 3Amp current limit. |
| Input voltage | 12V/24VDC +/- 5% |
| Power protection | Fuse fitted (Resettable) |
| DC Power handling | Reverse power polarity protection is equipped on the board |
| Storage temperature limits | -40°C to +70°C |
| Operating temperature limits | 0°C to +60°C |

NOTES

Please note the following:

- For specific panel setup a sample of an LCD may be required (this will be returned) and a copy of the full technical specifications for the panel from the manufacturer.
- Re-layout and custom development services are available.

APPENDIX I – SIGNAL SUPPORT MODE TABLE

ARGB (P1) PORT :

| Mode | Resolution | Clk [MHz] | Horizontal freq [KHz] | Vertical freq [Hz] | Sync Mode |
|-------|------------------|-----------|-----------------------|--------------------|-----------------------|
| T_70 | 720x400 70Hz | 28.322 | 31.469 | 70.087 | Digital Separate Sync |
| T_70 | 720x400 70Hz | 28.322 | 31.469 | 70.087 | Sync On Green |
| V_60 | 640x480 60Hz | 25.175 | 31.469 | 59.940 | Digital Separate Sync |
| V_60 | 640x480 60Hz | 25.175 | 31.469 | 59.940 | Sync On Green |
| V_60 | 640x480 60Hz | 25.175 | 31.469 | 59.940 | Composite Sync |
| V_72 | 640x480 72Hz | 31.500 | 37.861 | 72.809 | Digital Separate Sync |
| V_72 | 640x480 72Hz | 31.500 | 37.861 | 72.809 | Sync On Green |
| V_72 | 640x480 72Hz | 31.500 | 37.861 | 72.809 | Composite Sync |
| V_75 | 640x480 75Hz | 31.500 | 37.500 | 75.000 | Digital Separate Sync |
| V_75 | 640x480 75Hz | 31.500 | 37.500 | 75.000 | Sync On Green |
| V_75 | 640x480 75Hz | 31.500 | 37.500 | 75.000 | Composite Sync |
| SV_56 | 800x600 56Hz | 36.000 | 35.156 | 56.250 | Digital Separate Sync |
| SV_56 | 800x600 56Hz | 36.000 | 35.156 | 56.250 | Sync On Green |
| SV_56 | 800x600 56Hz | 36.000 | 35.156 | 56.250 | Composite Sync |
| SV_60 | 800x600 60Hz | 40.000 | 37.879 | 60.317 | Digital Separate Sync |
| SV_60 | 800x600 60Hz | 40.000 | 37.879 | 60.317 | Sync On Green |
| SV_60 | 800x600 60Hz | 40.000 | 37.879 | 60.317 | Composite Sync |
| SV_72 | 800x600 72Hz | 50.000 | 48.077 | 72.188 | Digital Separate Sync |
| SV_72 | 800x600 72Hz | 50.000 | 48.077 | 72.188 | Sync On Green |
| SV_72 | 800x600 72Hz | 50.000 | 48.077 | 72.188 | Composite Sync |
| SV_75 | 800x600 75Hz | 49.500 | 46.875 | 75.000 | Digital Separate Sync |
| SV_75 | 800x600 75Hz | 49.500 | 46.875 | 75.000 | Sync On Green |
| SV_75 | 800x600 75Hz | 49.500 | 46.875 | 75.000 | Composite Sync |
| X_60 | 1024x768 60Hz | 65.000 | 48.363 | 60.004 | Digital Separate Sync |

Specifications subject to change without notice

| | | | | | |
|--------|-------------------|--------|--------|--------|-----------------------|
| X_60 | 1024x768 60Hz | 65.000 | 48.363 | 60.004 | Sync On Green |
| X_60 | 1024x768 60Hz | 65.000 | 48.363 | 60.004 | Composite Sync |
| X_70 | 1024x768 70Hz | 75.000 | 56.476 | 70.069 | Digital Separate Sync |
| X_70 | 1024x768 70Hz | 75.000 | 56.476 | 70.069 | Sync On Green |
| X_70 | 1024x768 70Hz | 75.000 | 56.476 | 70.069 | Composite Sync |
| X_75 | 1024x768 75Hz | 78.750 | 60.023 | 75.029 | Digital Separate Sync |
| X_75 | 1024x768 75Hz | 78.750 | 60.023 | 75.029 | Sync On Green |
| X_75 | 1024x768 75Hz | 78.750 | 60.023 | 75.029 | Composite Sync |
| SX_60 | 1280x1024 60Hz | 108 | 63.81 | 60.020 | Digital Separate Sync |
| SX_60 | 1280x1024 60Hz | 108 | 63.81 | 60.020 | Sync On Green |
| SX_60 | 1280x1024 60Hz | 108 | 63.81 | 60.020 | Composite Sync |
| SX_75 | 1280x1024 75Hz | 135 | 79.976 | 75 | Digital Separate Sync |
| SX_75 | 1280x1024 75Hz | 135 | 79.976 | 75 | Sync On Green |
| SX_75 | 1280x1024 75Hz | 135 | 79.976 | 75 | Composite Sync |
| UX_60 | 1600x1200 60Hz | 162 | 75.000 | 60 | Digital Separate Sync |
| UX_60 | 1600x1200 60Hz | 162 | 75.000 | 60 | Sync On Green |
| UX_60 | 1600x1200 60Hz | 162 | 75.000 | 60 | Composite Sync |
| WUX_60 | 1920x1080 60Hz | 172.8 | 67.5 | 60 | Digital Separate Sync |
| WUX_60 | 1920x1080 60Hz | 172.8 | 67.5 | 60 | Sync On Green |
| WUX_60 | 1920x1080 60Hz | 172.8 | 67.5 | 60 | Composite Sync |
| WUX_60 | 1920x1200 60Hz | 193.2 | 74.5 | 60 | Digital Separate Sync |
| WUX_60 | 1920x1200 60Hz | 193.2 | 74.5 | 60 | Sync On Green |
| WUX_60 | 1920x1200 60Hz | 193.2 | 74.5 | 60 | Composite Sync |

Remark :

The controller has been designed to take a very wide range of input signals however to optimize the PC's graphics performance we recommend choosing 60Hz vertical refresh rate. To support on higher refresh rate over 60Hz, the LCD panel may not support.

COMPOSITE, S-VIDEO & COMPONENT VIDEO INPUT PORT :

| System | Resolution | Horizontal freq [KHz] | Vertical freq [Hz] |
|-----------|------------|-----------------------|--------------------|
| NTSC | 720x480i | 15.7 | 60 |
| NTSC 4.43 | 720x480i | 15.7 | 60 |
| PAL | 720x576i | 15.6 | 50 |
| PAL M | 720x576i | 15.6 | 50 |
| SECAM | 720x576i | 15.6 | 50 |

HDMI / DVI / Auxiliary digital video (HD1&HD2) input port :

| Mode | Resolution | Clk [MHz] | Horizontal freq [KHz] | Vertical freq [Hz] |
|---------|------------------|-----------|-----------------------|--------------------|
| T_70 | 720x400 70Hz | 28.322 | 31.469 | 70.087 |
| V_60 | 640x480 60Hz | 25.175 | 31.469 | 59.940 |
| V_67 | 640x480 67Hz | 31.5 | 37.5 | 67 |
| V_75 | 640x480 75Hz | 31.5 | 37.5 | 75 |
| SV_56 | 800x600 56Hz | 36 | 35.156 | 56 |
| SV_60 | 800x600 60Hz | 40.000 | 37.879 | 60.317 |
| SV_72 | 800x600 72Hz | 50 | 48.077 | 72 |
| SV_75 | 800x600 75Hz | 49.5 | 46.875 | 75 |
| X_60 | 1024x768 60Hz | 65.000 | 48.363 | 60.004 |
| X_70 | 1024x768 70Hz | 75 | 56.476 | 70 |
| X_75 | 1024x768 75Hz | 78.75 | 60.023 | 75 |
| SX_60 | 1280x1024 60Hz | 108 | 63.81 | 60.020 |
| SX_75 | 1280x1024 75Hz | 135 | 79.976 | 75 |
| UX_60 | 1600x1200 60Hz | 162 | 75.000 | 60 |
| WUX_60 | 1920x1080 60Hz | 172.8 | 67.5 | 60 |
| WUX_60 | 1920x1200 60Hz | 193.2 | 74.5 | 60 |
| 1080p60 | 1920x1080p 60Hz | 135 | 67.5 | 60 |
| 1080p59 | 1920x1080 59Hz | 148.35 | 67.433 | 60 |
| 1080p50 | 1920x1080 50Hz | 149 | 62.75 | 50 |
| 1080i60 | 1920x1080i 60Hz | 74.14 | 33.7 | 60 |
| 1080i50 | 1920x1080i 50Hz | 74.184 | 28.1 | 50 |
| 1080i24 | 1920x1080i 24Hz | 74.25 | 27 | 24 |
| 1080i23 | 1920x1080i 23 Hz | 74.25 | 27 | 23 |
| 720p60 | 1280x720P 60Hz | 74.25 | 45 | 60 |
| 576p50 | 720x576P 50Hz | 26.9568 | 31.2 | 50 |
| 480p60 | 720x480P 60Hz | 26.9568 | 31.4 | 60 |

Appendix II – RS-232 control protocols

RS-232 Serial control (Baud rate 2400, 8 bits, 1 stop bit and no parity)

Physical connection :

Controller side

Connector interface : CN8 / CN1

Mating connector : JST XHP-6

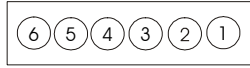

Mating face of CN8

Computer side

Connector interface : Serial port

Mating connector : DB9 Female

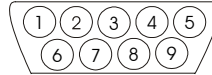

Mating face of RS-232 DB9 Male

| PIN# | Description |
|------|----------------|
| 4 | RS-232 Tx Data |
| 5 | Ground |
| 6 | RS-232 Rx Data |

| PIN# | Description |
|------|----------------|
| 2 | RS-232 Rx Data |
| 3 | RS-232 Tx Data |
| 5 | Ground |

Remark :

(1) : RS-232 connection cable, 600mm P/N 4260902-00 can be ordered separately for connection.

Software connection :

The OSD function can be controlled through sending the RS-232 protocol.

The RS-232 program can be custom-made to fit for application or it can be used the serial control program, like Accessport, Telix or Serial Utility program developed by DigitalView. Please contact your local support for information.

1. Commands to implement switch mount control buttons

| Function | Command | Description | Remark |
|--------------------|---------|----------------------------|-------------------|
| Menu button | 0xf7 | Menu button pressed | Button equivalent |
| Select-down button | 0xfa | Select-down button pressed | Button equivalent |
| Select-up button | 0xfb | Select-up button pressed | Button equivalent |
| Right/+ button | 0xfc | Right/+ button pressed | Button equivalent |
| Left/- button | 0xfd | Left/- button pressed | Button equivalent |

2. Parameter setting - immediate, relative, reset and query

| Function | Command | Description | Acknowledge (if enabled) |
|-------------------------------------|---|---|--|
| Volume control - left+right channel | 0x80, "a" "A", nn "+" "-" "r" "R" "?" | Set audio (L+R) volume = value/increment/decrement Reset Query | volume Range : "0"0"-1"E" Default : "0"0"F" |
| Volume control - on/off (mute) | 0x80, "m" "M", "0" "1" "r" "R" "?" | Disable audio output. Enable audio output. Reset Query | "0" - audio off (muted). "1" - audio on. |
| Brightness control | 0x81, nn "+" "-" "r" "R" "?" "m" "n" "i", ss, nn "o", ss, | Set brightness = value/increment/decrement Reset Query Current Source Maximum query *1 Minimum query *1 Set, Source, value *1 Query, Source *1 | Brightness. Range : "4"E"-B"2" Default : "8"0" ss - reference by Input main select(0x98) |
| Contrast control - all channels | 0x82, "a" "A", nn "+" "-" "r" "R" "?" "m" "n" "i", ss, nn "o", ss, | Set all contrast = value/increment/decrement Reset Query Maximum query *1 Minimum query *1 Set, Source, value *1 Query, Source *1 | Contrast Range : "1"C"-E"4" Default : "8"0" ss - reference by Input main select(0x98) |
| Saturation control | 0x83, nn "+" "-" "r" "R" "?" "m" "n" "i", ss, nn "o", ss, | Set color = value/increment/decrement Reset Query Maximum query *1 Minimum query *1 Set, Source, value *1 Query, Source *1 | PAL/NTSC color (In video mode only) Range : "0"1"-F"F" Default : "8"0" ss - reference by Input main select(0x98) |
| Hue control | 0x84, nn "+" "-" "r" "R" "?" "m" "n" "i", ss, nn "o", ss, | Set tint = value/increment/decrement Reset Query Maximum query *1 Minimum query *1 Set, Source, value *1 Query, Source *1 | NTSC tint (In NTSC mode only) Range : "5"3"-9"F" Default : "7"9" ss - reference by Input main select(0x98) |
| Phase (tuning) control | 0x85, nn "+" "-" "?" | Set dot clock phase = value/increment/decrement Query | Dot clock phase. (In PC mode only) |
| Image H position | 0x86, | Set img_hpos = | Image horizontal position. |

Specifications subject to change without notice

| | | | |
|------------------------|--|--|---|
| | nnnn "+" "-" "?" | value/increment/decrement Query | (In PC mode only) |
| Image V position | 0x87, nnnn "+" "-" "?" | Set img_vpos = value/increment/decrement Query | Image vertical position. (In PC mode only) |
| Sharpness | 0x8a, nn "+" "-" "r" "R" "?" | Set sharpness = value/increment/decrement Reset Query | Sharpness. (Video Mode Source only) Range : "F"4-"0"0C Default : "0"0 |
| Frequency | 0x8b, nnnn "+" "-" "?" | Set frequency = Value/increment/decrement Query | Graphic mode H active size (in pixels) |
| Scaling Mode | 0x8c, "0" "1" "2" "3" "9" "A" "B" "C" "D" "r" "R" "?" | Set graphic image scaling mode = value Reset Query | Image expansion on/off. "0" – 1:1 "1" – fill screen "2" – fill to aspect ratio "9" – 4:3 "A" – 16:9 "B" – 16:10 "C" – 2.35:1 "D" – 2:1 |
| OSD H position | 0x90, nnn "+" "-" "r" "R" "?" | Set osd_hpos = value/increment/decrement Reset Query | OSD horizontal position. Range : "0"0-"F"0F Default : "8"0 |
| OSD V position | 0x91, nnn "+" "-" "r" "R" "?" | Set osd_vpos = value/increment/decrement Reset Query | OSD vertical position. Range : "0"0-"F"0F Default : "8"0 |
| OSD Transparency | 0x92, n "+" "-" "r" "R" "?" | Set OSD transparency = value/increment/decrement Reset Query | OSD transparency. "0" – ON "1" – OFF |
| OSD menu timeout | 0x93, nn "+" "-" "r" "R" "?" | Select menu timeout = value/increment/decrement Reset Query | OSD menu timeout value. "0"0 – Continuous. value – Round up to nearest available step. if value > max available step, set it to the max available step. Range : "0"5-"3"0C Default : "0"0A |
| Select OSD language | 0x95, n "r" "R" "?" | Select language = English, Chinese,... Reset Query | "0" – English. "2" – French "3" – Spanish "6" – German "8" – Chinese |
| Input main select | 0x98, nn "+" "-" "r" "R" "?" | Select input main = PC or VIDEO or next available Reset Query | Main selected. "0x41,0x31" ARGB "0x42,0x31" Composite "0x42,0x32" Composite2 "0x43,0x31" S-video "0x43,0x32" S-video2 "0x44,0x31" Component "0x44,0x32" Component2 "0x45,0x31" HDSDI "0x45,0x32" HDSDI2 "0x46,0x31" DVI "0x48,0x31" HDMI |
| Auto Source Seek | 0x99, nn , | Set Auto source enable = *1 Source | "nn" = "0x41,0x31"- ARGB |

| | | | |
|--|---|--|--|
| | "0" "1" "?" "o" | Disable/ Enable Query Valid Source query | "0x42,0x31"- Composite "0x42,0x32"- Composite 2 "0x43,0x31"- S-video "0x43,0x32"- S-video 2 "0x44,0x31"- Component "0x44,0x32"- Component 2 "0x45,0x31"- HDS DI "0x45,0x32"- HDS DI2 "0x46,0x31"- DVI "0x48,0x31" HDMI |
| Source Layout | 0x9a, n "r" "R" "?" | Select source layout = Single, PIP, PBP, PBPT Reset, Query | Query: "0"- Single "1"- Picture in Picture (PIP) "2"- Picture by Picture (PBP) "3"- Picture by Picture Tall (PBPT) |
| Video System (Composite, S- video and Component Only) | 0x9b, "0" "1" "2" "3" "r" "R" "S" "s" "?" | Set video system = Auto/NTSC/PAL/SECAM Reset Video State Query Query | Query "0" – Auto. "1" – NTSC_M_358 "2" – PAL_N_443 "3" – SECAM "4" – NTSC_M_443 "5" - PAL_M_358 "7" – PAL_M_443 "9" – PAL_N_358 <hr/> Video State Query "0" – No video. "1" – NTSC "2" – PAL "3" – SECAM "4" – NTSC 443 "5" – PAL M 358 |
| GAMMA value select | 0x9d, n "r" "R" "?" | Select GAMMA value = Value Reset Query | GAMMA value: "0" – 1.0, "1" – 1.6 "2" – 2.2, "3" – User Defined "4" – 1.7, "5" – 1.8, "6" – 1.9, "7" – 2.0, "8" – 2.1, "9" – 2.3, "A" – 2.4, "B" – 2.5, "C" – 2.6, "D" – 0.6, "E" – 0.7, "F" – 0.8, "G" – 0.9, "H" – 1.1, "I" – 1.2, "J" – 1.3, "K" – 1.4, "L" – 1.5 |
| Auto power off | 0x9f, "0" "1" "r" "R" "?" | Set power down option = On/Off Reset Query | "0" – Off. "1" – On. |
| Hotkey 1 | 0xa0, "1", n "r" "R" "?" | Set Hotkey 1= Value Reset Query | "1" – volume. "2" – brightness. "3" – contrast. "4" – colour. "5" – input source. "7" – zoom "8" – freeze "9" – PIP "B" – No function "D" – PIP Swap |

| | | | |
|------------------------|--|--|---|
| | | | <p>"E" – Aspect Ratio "G" – Hue "H" – Backlight "I" – Auto Picture Setup</p> |
| Hotkey 2 | 0xa0, "2", n "r" "R" "?" | Set Hotkey 2 = value Reset Query | <p>"1" – volume. "2" – brightness. "3" – contrast. "4" – colour. "5" – input source. "7" – zoom "8" – freeze "9" – PIP "B" – No function "D" – PIP Swap "E" – Aspect Ratio "G" – Hue "H" – Backlight "I" – Auto Picture Setup</p> |
| Runtime counter | 0xa1, nnnnn "r" "R" "?" | runtime counter value = nnnnn (* 0.5 hour) Reset Query | Runtime = nnnnn. |
| PIP brightness control | 0xa2, nn "+" "-" "r" "R" "?" | Set PIP window brightness = value/increment/decrement Reset Query | PIP window brightness. Range : "4" "E" - "B" "2" Default : "8" "0" |
| PIP contrast control | 0xa3, nn "+" "-" "r" "R" "?" | Set PIP window contrast = value/increment/decrement Reset Query | PIP window contrast. Range : "1" "C" - "E" "4" Default : "8" "0" |
| PIP H position | 0xa4, nnn "+" "-" "r" "R" "?" | Set PIP_hpos = value/increment/decrement Reset Query | PIP window horizontal position. Range : "0" "0" "0" "0" - "0" "6" "4" Default : "0" "5" "5" |
| PIP V position | 0xa5, nnn "+" "-" "r" "R" "?" | Set PIP_vpos = value/increment/decrement Reset Query | PIP window vertical position. Range : "0" "0" "0" "0" - "0" "6" "4" Default : "0" "1" "4" |
| PIP window size select | 0xa6, nn "r" "R" "?" | Select PIP window size = PIP window size value Reset Query | Main selected. PIP off if "nn" = "0" "0". "0" "0" ~ "1" "2" "0" "0" ~ "1" "2" "1" "9" : Size by Size "1" "A" : Size by Size Tall |
| PIP source select | 0xa7, n "r" "R" "?" | Select input main = Video source value Reset Query | Main selected. 0x40, 0x30 : PIP OFF 0x41, 0x31 : ARGB 0x42, 0x31 : Composite 0x43, 0x31 : S-video 0x44, 0x31 : Component 1 0x45, 0x31 : HDSDI 1 0x46, 0x31 : DVI 0x42, 0x32 : Composite 2 0x43, 0x32 : S-video 2 0x44, 0x32 : Component 2 0x45, 0x32 : HDSDI 2 "0x48,0x31" HDMI |
| Zoom level | 0xa8, nnnn "+" "-" | Set Zoom level = value/increment/decrement | Zoom level. |

| | | | |
|---|--|--|---|
| | "r" "R" "?" | Reset Query | Min : 0x30 0x30 0x30 0x30 (Default) Max : 0x30 0x30 0x41 0x33 |
| Zoom H position | 0xa9, nnnn "+" "-" "r" "R" "?" | Set Zoom_hpos = value/increment/decrement Reset Query | Zoom window horizontal position. Default : 0x30 0x30 0x30 0x30 The min and max values will change depends on input resolution. |
| Zoom V position | 0xaa, nnnn "+" "-" "r" "R" "?" | Set Zoom_vpos = value/increment/decrement Reset Query | Zoom window vertical position. Default : 0x30 0x30 0x30 0x30 The min and max values will change depends on input resolution. |
| Horizontal Size | 0xad, nnn "+" "-" "r" "R" "?" | Set horizontal size for Aspect Size = value/increment/decrement Reset Query | Scalar horizontal stretch PAL(576i) / NTSC (480i) : Min : 0x30 0x30 0x30 (Default) Max : 0x30 0x46 0x30 |
| Vertical Size | 0xb0, nnn "+" "-" "r" "R" "?" | Set Vertical Size for Aspect Size = value/increment/decrement Reset Query | Scalar vertical stretch. PAL(576i) / NTSC (480i) : Min : 0x30 0x30 0x30 (Default) Max : 0x30 0x46 0x30 |
| Horizontal Pan | 0xb1, nnn "+" "-" "r" "R" "?" | Set horizontal pan position for Aspect Size = value/increment/decrement Reset Query | Scalar horizontal pan position PAL(576i) / NTSC (480i) : Assume max H-Size & max V- size : Min : 0x46 0x38 0x38 Max : 0x30 0x37 0x38 Default : 0x30 0x30 0x30 The min and max values will change depends on different value of H-Size, V-Size and input resolution. |
| Vertical Pan | 0xb2, nnn "+" "-" "r" "R" "?" | Set Vertical pan position for Aspect Size = value/increment/decrement Reset Query | Scalar vertical pan position PAL(576i) / NTSC (480i) : Assume max H-Size & max V- size : Min : 0x46 0x38 0x38 Max : 0x30 0x37 0x38 Default : 0x30 0x30 0x30 The min and max values will change depends on different value of H-Size, V-Size and input resolution. |
| Colour temperature select | 0xb3, n "r" "R" "?" | Select colour temperature = value Reset Query | Main selected. "0" – 9500K. "1" – 8000K. "2" – 6500K. "3" – 5000K "4" - User |
| Red level for selected colour temperature | 0xb4, nn "+" "-" "r" "R" "?" | Set the level of the red channel for the selected colour temp. = value/increment/decrement Reset Query | Red level for selected colour temperature. Range : "9"°C-"F"°F Default : "E"°C |

| | | | |
|---|---|---|--|
| | <p>"m" "n" "i" , ss, c, nn "o", ss, c</p> | <p>Maximum query *1 Minimum query *1 Set, Source, Temperature Group, value *1 Query, Source *1</p> | <p>c – reference by Color Temperature ss - reference by Input main select(0x98)</p> |
| Green level for selected colour temperature | <p>0xb5, nn "+" "-" "r" "R" "?" "m" "n" "i" , ss, c, nn "o", ss, c</p> | <p>Set the level of the green channel for the selected colour temp. = value/increment/decrement Reset Query Maximum query *1 Minimum query *1 Set, Source, Temperature Group, value *1 Query, Source *1</p> | <p>Green level for selected colour temperature Range : "9" "C" - "F" "F" Default : "E" "C" c – reference by Color Temperature ss - reference by Input main select(0x98).</p> |
| Blue level for selected colour temperature | <p>0xb6, nn "+" "-" "r" "R" "?" "m" "n" "i" , ss, c, nn "o", ss, c</p> | <p>Set the level of the blue channel for the selected colour temp. = value/increment/decrement Reset Query Maximum query *1 Minimum query *1 Set, Source, Temperature Group, value *1 Query, Source *1</p> | <p>Blue level for selected colour temperature. Range : "9" "C" - "F" "F" Default : "E" "C" c – reference by Color Temperature ss - reference by Input main select(0x98).</p> |
| Graphic horizontal resolution enquiry | 0xb7 | Horizontal resolution (in pixels) in 3 digit hex number | "nnn" = horizontal resolution |
| Graphic vertical resolution enquiry | 0xb8 | Vertical resolution (in lines) in 3 digit hex number | "nnn" = vertical resolution |
| Graphic horizontal sync frequency enquiry | 0xb9 | Horizontal sync frequency (in units of 100Hz) in 3 digit hex number | "nnn" = horizontal frequency |
| Graphic vertical sync frequency enquiry | 0xba | Vertical sync frequency (in units of Hz) in 3 digit hex number and 1 char | "nnnn" = vertical frequency nnn = 3 digit hex c= "i" or "p" interlace or Progressive 0xba added the interlace(i) or Progressive(p) feedback. |
| OSD status enquiry | 0xbb | Status of OSD | "0" – OSD turned off "1" – OSD turned on "2" – Text Overlay on "3" – Display Mark on "4" – Screen Marker on |
| Display Video Source Select | 0xbc, "?" "0" "1" | Display Video source select Query Name of video source not displayed. After switching to a new video source, the name of the video source is displayed for 5 seconds. | "0" – Disabled. "1" – Enabled. |
| OSD turn off | 0xbd | Turn off the OSD. | "0" – fail. "1" – successful. |
| Set gamma data for user defined gamma curve | 0xbf, mm, c, "?" 0xbf, "R" "r" 0xbf, mm, c, nn | Query gamma data for color c index mm (c = 0 for color Red, c=1 for color Green, c=2 for color Blue) Set user gamma curve to linear Set gamma data for color c | "nn" = gamma data "1" "nn" = gamma data |

| | | | |
|---|--|--|---|
| | | index mm. (If c= 3, then gamma data for red, green & blue will be set at the same time.) | |
| Query External Memory | 0xcb, "2" | Check External Memory 24c256 | "0" – Not Installed "1" – Installed "?" – Not Support |
| Query Revision Number | 0xcb, "3" | Read Revision Number | "nn" = Revision number |
| Backlight control | 0xe0, nn "+" "-" "R" "r" "?" | Set Backlight = value/increment/decrement Reset Query | Backlight. Range: D/A : "0"0" ~ "1"0" 100Hz : "0"0" ~ "B"0" 120Hz : "0"0" ~ "9"0" 140Hz : "0"0" ~ "8"8" 160Hz : "0"0" ~ "7"7" 180Hz : "0"0" ~ "6"A" 200Hz : "0"0" ~ "5"0" 220Hz : "0"0" ~ "5"6" 240Hz : "0"0" ~ "4"0" 260Hz : "0"0" ~ "4"9" 280Hz : "0"0" ~ "4"4" 300Hz : "0"0" ~ "3"0" 320Hz : "0"0" ~ "3"B" 340Hz : "0"0" ~ "3"7" 360Hz : "0"0" ~ "3"4" 380Hz : "0"0" ~ "3"1" 400Hz : "0"0" ~ "2"0" 420Hz : "0"0" ~ "2"D" 440Hz : "0"0" ~ "2"B" |
| Backlight On/Off | 0xe1, "0" "1" "R" "r" "?" "S" "s" | Backlight Off / Backlight On /Status | "0" – Backlight Off "1" – Backlight On. "?" – Backlight On/Off Query "S" "s" – Backlight Status Query |
| Color Monochrome mode selection (Output Channel Select) | 0xe2 "0" "1" "2" "3" "4" "5" "6" "R" "r" "?" | Off/ Blue Only/ Red Only/ Green Only/ Blue Mono/ Red Mono/ Green Mono/ | "0" – Off "1" – Blue Only "2" – Red Only "3" – Green Only "4" – Blue Mono "5" – Red Mono "6" – Green Mono |
| PIP Swap | 0xe3 | Swap Main and PIP source | "0" - Fail. "1" - Successful. |
| Backlight D/A / PWM | 0xe5 "0" "1" "R" "r" "?" | Set : PWM or D/A Reset Query | "0" – PWM "1" – D/A |
| Backlight PWM Frequency | 0xe6, nnn "+" "-" "R" "r" "?" | Set Backlight PWM Frequency = value/increment/decrement Reset Query | +/- 20Hz Value 100Hz : "0", "6", "4" 120Hz : "0", "7", "8" 140Hz : "0", "8", "C" 160Hz : "0", "A", "0" 180Hz : "0", "B", "4" 200Hz : "0", "C", "8" 220Hz : "0", "D", "C" 240Hz : "0", "F", "0" 260Hz : "1", "0", "4" 280Hz : "1", "1", "8" 300Hz : "1", "2", "C" |

| | | | |
|--|---|---|---|
| | | | 320Hz : "1","4","0" 340Hz : "1","5","4" 360Hz : "1","6","8" 380Hz : "1","7","C" 400Hz : "1","9","0" 420Hz : "1","A","4" 440Hz : "1","B","8" |
| Backlight Invert | 0xe7 "0" "1" "R" "r" "?" | Set On or Off Reset Query | "0" – Off "1" – On |
| Red Offset for selected colour temperature | 0xe8, nn "+" "-" "r" "R" "?" "m" "n" "i", ss, c, nn "o", ss, c | Set the Offset of the red channel for the selected colour temp. = value/increment/decrement Reset Query Maximum query *1 Minimum query *1 Set, Source, Temperature Group, value *1 Query, Source *1 | Red Offset for selected colour temperature. c – reference by Color Temperature ss - reference by Input main select(0x98) |
| Green Offset for selected colour temperature | 0xe9, nn "+" "-" "r" "R" "?" "m" "n" "i", ss, c, nn "o", ss, c | Set the Offset of the green channel for the selected colour temp. = value/increment/decrement Reset Query Maximum query *1 Minimum query *1 Set, Source, Temperature Group, value *1 Query, Source *1 | Green Offset for selected colour temperature. c – reference by Color Temperature ss - reference by Input main select(0x98) |
| Blue Offset for selected colour temperature | 0xea, nn "+" "-" "r" "R" "?" "m" "n" "i", ss, c, nn "o", ss, c | Set the Offset of the blue channel for the selected colour temp. = value/increment/decrement Reset Query Maximum query *1 Minimum query *1 Set, Source, Temperature Group, value *1 Query, Source *1 | Blue Offset for selected colour temperature. c – reference by Color Temperature ss - reference by Input main select(0x98) |
| PIP Window Blend Level | 0xed, nn "+" "-" "R" "r" "?" | Select PIP Transparency Level PIP Transparency value Reset Query | PIP Transparency "0"F" = 6.25% "0"E" = 12.5% "0"D" = 18.75% "0"C" = 25% "0"B" = 31.25% "0"A" = 37.5% "0"9" = 43.75% "0"8" = 50% "0"7" = 56.25% "0"6" = 62.5% "0"5" = 68.75% "0"4" = 75% "0"3" = 81.25% "0"2" = 87.5% "0"1" = 93.75% "0"0" = 100%. |
| PIP Window Auto Off | "0xee", "0x41" "0" "1" "?" | Auto Off / Auto On Query | "0"- Off "1"- On |
| ScreenMarker | "0xee", "0x42" "0" "1" | Screen Marker Off / Screen Marker On | "0"- Off "1"- On |
| CenterMarker | "0xee", "0x43" "0" "1" | Center Marker Off / Center Marker On | "0"- Off "1"- On |

| | | | |
|--------------------------------|--|---|--|
| AspectMarker | "0xee", "0x44" "0" "1" | Preliminary 4:3 /16:9 | "0"- 4:3 "1"- 16:9 |
| Marker Background Transparency | "0xee", "0x45" "0" "1" "2" "3" | Preliminary 0% /25%/50%/95% | "0"- 0% "1"- 25% "2"- 50% "3"- 95% |
| Safe Area Marker* | "0xee", "0x47" "0x53"~"0x63" | Preliminary 80%~99% | "36", "33"- 99% "36", "32"- 98% "36", "31"- 97% "36", "30"- 96% "35", "46"- 95% "35", "45"- 94% "35", "44"- 93% "35", "43"- 92% "35", "42"- 91% "35", "41"- 90% "35", "39"- 89% "35", "38"- 88% "35", "37"- 87% "35", "36"- 86% "35", "35"- 85% "35", "34"- 84% "35", "33"- 83% "35", "32"- 82% "35", "31"- 81% "35", "30"- 80% |
| IR Lock* | "0xee", "0x48" n "0" "1" "r" "R" "?" | IR Lock Disable / IR Lock Enable Reset Query | "0" – IR Lock Disable "1" – IR Lock Enable |
| Light Detector | "0xee", "0x4A" "0" "1" "R" "r" "?" "S" "s" | Light Detector Off / Light Detector On Light Detector On/Off Query Light Detector Value Query | "0" –Light Detector Off "1" –Light Detector On. "?" – Light Detector On/Off Query "S" "s" –Light Detector Value Query 0x00~0xFF |
| Safe Area Marker Enable | "0xee", "0x4B" "0" "1" | Safe Area Marker Off / Safe Area Marker On | "0"- Off "1"- On |
| Aspect Marker Enable | "0xee", "0x4C" "0" "1" | Aspect Marker Off / Aspect Marker On | "0"- Off "1"- On |
| Display real time clock | "0xee", "0x4D" "0" "1" | Real Time Clock Display Off / Real Time Clock Display | "0"- Off "1"- On |
| Custom Sizing | 0xef, "0" "1" "2" "?" | Custom sizing selection : Overscan / Normal / Custom Query | "0" – Overscan "1" – Custom / Underscan "2" – Normal |

| Function | Command | Description | Acknowledge (if enabled) |
|---|--|---|---|
| Send Display Mark | 0xF1, "S" "0x21" "0x40" "0x60" "0x7E" Return "1" | "S" = "0x53 or 0x73" ASCII "0x21,0x40,0x60,0x7E" Return " 0x31" | "S" – Send Command "Text" – Character "1" - successful. |
| e.g Send Display Mark RS232 Code: "0xF1 0x53 0x21" Return Code: "0xF1 0x53 0x21 0x31" | | | |
| Clear Display Mark | 0xF1, "C" Return "1" | "C" = "0x43 or 0x63" Return " 0x31" | "C" – Clear command "1" - successful. |

Specifications subject to change without notice

| | | | |
|---|------------------------------------|--|---|
| e.g Clear Display Mark RS232 Code: "0xF1 0x43" Return Code: "0xF1 0x43 0x31" | | | |
| Display Mark Horizontal Position | 0xF1, "H" "ss" Return "nn" | "H" = "0x48 or 0x68" ----- "nn" = "0x30,0x30~0x46,0x46" | "H" – Horizontal Position command "ss" – Set Horizontal Position number "nn" – Return Position number |
| e.g Set Display Mark Horizontal Position RS232 Code: "0xF1 0x48 0x30 0x31" Return Code: "0xF1 0x48 0x30 0x31 0x30 0x31" | | | |
| Display Mark Vertical Position | 0xF1, "V" "ss" Return "nn" | "V" = "0x56 or 0x76" ----- "nn" = "0x30,0x30~0x46,0x46" | "V" – Vertical Position command "ss" – Set Vertical Position number "nn" – Return Position number |
| e.g Set Display Mark Vertical Position RS232 Code: "0xF1 0x56 0x30 0x31" Return Code: "0xF1 0x56 0x30 0x31 0x30 0x31" | | | |
| Display Mark Background Transparency | 0xF1, "B" "N" Return "n" | "B" = "0x42 or 0x62" Set Transparency command ----- "N" = "0x30~0x46" Transparency Value (Rang 00~0F) | "B" - Transparency command "N" – Transparency Value "n"- Return Value 0x00 =opaque |
| Set Display Mark background Transparency value is 8 RS232 Code: "0xF1 0x42 0x38" Return Code: "0xF1 0x42 0x38 0x38" | | | |

3. Other control

| Function | Command | Description | Acknowledge (if enabled) |
|---------------------------|-----------------------------|--|--|
| Select RS-232 acknowledge | 0xc1, "0" "1" | Disable/enable command acknowledge. | "0" – acknowledge disabled. "1" – acknowledge enabled. |
| Auto-setup | 0xc3 | Start auto-setup of current vmode. | "0" – fail. "1" – successful. |
| Command availability | 0xc4, n | Check whether a command is available. | "0" – not available. "1" – available. |
| Auto-calibration | 0xc5 | Start auto-calibration of gain of the RGB amplifier. | "0" – fail. "1" – successful. |
| Freeze frame | 0xc6, "0" "1" | Unfreeze / freeze frame | "0" – unfreeze. "1" – freeze. |
| Soft Power On/Off | 0xc8, "0" "1" "?" | Soft power off/on query | "0" – Turn off the LCD power and backlight. Turn off memory controller, Power down DVI Power down ADC, Power down Fclk PLL "1" – Turn on the unit |
| Query video input status | 0xc9 | Query the status of the primary & pip status | "nn,nn" = input status "nn,xx" digit = primary status: "0", "0" : invalid "A", "1" ARGB "B", "1" Composite "B", "2" Composite 2 "C", "1" S-video "C", "2" S-video 2 "D", "1" Component "D", "2" Component 2 "E", "1" HDS DI "E", "2" HDS DI 2 |

| | | | |
|---|---|---|--|
| | | | <p>"F", "1" DVI "H" "1" HDMI</p> <p>"xx,nn"= PIP input status: "0", "0": invalid "A", "1" ARGB "B", "1" Composite "B", "2" Composite 2 "C", "1" S-video "C", "2" S-video 2 "D", "1" Component "D", "2" Component 2 "E", "1" HDSDI "E", "2" HDSDI 2 "F", "1" DVI "H" "1" HDMI</p> |
| Video de-interlace method | 0xca, "0" "1" "r" "R" "?" | De-interlace mode Reset Query | <p>"3" "1"- enable AFM "3" "0"- disable AFM "4" "1"- enable TNR "4" "0"- disable TNR "5" "1"- enable MADI "5" "0"- disable MADI "7" "1"- enable DCDi "7" "0"- disable DCDi</p> |
| Query BIOS version | 0xcb, "0" | Read BIOS version | <p>BIOS version "VV.YY.ZZ" VV = V0 or E0, V0 = Release version E0 = Engineering Sample</p> <p>YY= Version Number</p> <p>ZZ= Customer Number</p> |
| Query PCBA number | 0xcb, "1" | Read PCBA number | <p>"nnnnn" = PCBA number SVX-1920= "41721"</p> |
| Reset to Factory Defaults | 0xce | Reset all parameters to default value | "1" – successful. |
| Reset to Factory Defaults with (color temp) | 0xcf | Reset all parameters for all video modes to default value | "1" - successful. |
| Saved Calibrated default | 0xd7 | Saving all parameters to user default value | "1" - successful. |
| Load Calibrated default | 0xd8 | Loading all parameters to user default value | <p>"1" - successful. "0" - not successful "E" – Checksum Error</p> |
| Wide Screen Mode Selection | 0xd9, "0" "1" "2" "r" "R" "?" | Wide Screen Mode Reset Query | <p>"0" – Normal Mode "1" – 1280x768 "2" – 1366x768</p> |

| | | | |
|--------------------------------|---|--------------------------------------|--|
| ScreenMarker | "0xee", "0x42" "0" "1" | Screen Marker Off / Screen Marker On | <p>"0"- Off "1"- On</p> |
| CenterMarker | "0xee", "0x43" "0" "1" | Center Marker Off / Center Marker On | <p>"0"- Off "1"- On</p> |
| AspectMarker | "0xee", "0x44" "0" "1" | Preliminary 4:3 /16:9 | <p>"0"- 4:3 "1"- 16:9</p> |
| Marker Background Transparency | "0xee", "0x45" "0" "1" "2" "3" | Preliminary 0% /25%/50%/95% | <p>"0"- 0% "1"- 25% "2"- 50%</p> |

Specifications subject to change without notice

| | | | |
|------------------|---------------------------------|------------------------|--|
| | | | "3"- 95% |
| Safe Area Marker | "0xee", "0x46" "0x53"~"0x63" | Preliminary 64%~98% | "36", "33"- 98% "36", "32"- 96% "36", "31"- 94% "36", "30"- 92% "35", "46"- 90% "35", "45"- 88% "35", "44"- 86% "35", "43"- 84% "35", "42"- 83% "35", "41"- 81% "35", "39"- 79% "35", "38"- 77% "35", "37"- 76% "35", "36"- 74% "35", "35"- 72% "35", "34"- 71% "35", "33"- 69% "35", "32"- 67% "35", "31"- 66% "35", "30"- 64% |

The following commands for sending texts by using RS-232 command.

| Function | Command | Description | Acknowledge (if enabled) |
|---|---|--|---|
| Send Line | 0xF0, ”S” ”LL” ”TEXT” ”0x0A” Return ”1” | ”S” = ”0x53 or 0x73” Send command ----- - ”LL” = ”0x30,0x31~0x30,0x34” Line number (Rang 0~4 lines) ----- - ”Text”= ASCII code, ”0x20~0x7E” Character(Rang 0~34) ----- - 0x0A = End of line | ”S” – Send Command ”LL” – Line Number ”Text” – Character ”0x0A” – End of Line ”1” - successful. |
| e.g Display ”Send Text” message on screen: RS232 Code:”0xF0 0x53 0x30 0x31 0x53 0x65 0x6E 0x64 0x20 0x54 0x65 0x78 0x74 0x0A” Return Code: ”0xF0 0x53 0x30 0x31 0x53 0x65 0x6E 0x64 0x20 0x54 0x65 0x78 0x74 0x0A 0x31” | | | |
| Clear Line | 0xF0, ”C” ”LL” Return ”nn” | ”C” = ”0x43 or 0x63” Clear command ----- - ”LL” = ”0x30,0x31~0x30,0x34” Line number (Rang 0~4 lines) | ”C” – Clear command ”LL” – Line Number ”nn” – Return Line number |
| e.g Clear Line 1 RS232 Code: ”0xF0 0x43 0x30 0x31” Return Code: ”0xF0 0x43 0x30 0x31 0x30 0x31” | | | |
| Text Window Horizontal Position | 0xF0, ”H” ”ss” Return ”nn” | ”H” = ”0x48 or 0x68” ----- --”nn” = ”0x30,0x30~0x46,0x46” | ”H” – Horizontal Position command ”ss” – Set Horizontal Position number ”nn” – Return Position number |
| e.g Set Text Window Horizontal Position RS232 Code: ”0xF0 0x48 0x30 0x31” Return Code: ”0xF0 0x48 0x30 0x31 0x30 0x31” | | | |
| Text Window Vertical Position | 0xF0, ”V” ”ss” Return ”nn” | ”V” = ”0x56 or 0x76” ----- --”nn” = ”0x30,0x30~0x46,0x46” | ”V” – Vertical Position command ”ss” – Set Vertical Position number ”nn” – Return Position number |
| e.g Set Text Window Vertical Position RS232 Code: ”0xF0 0x56 0x30 0x31” Return Code: ”0xF0 0x56 0x30 0x31 0x30 0x31” | | | |

| | | | |
|---|--------------------------------------|---|---|
| Left offset | 0xF0, "O" "SSS" Return "nnn" | "O" = "0x4F or 0x6F" Set Left Offset command ----- - "SSS" = "0x30,0x30,0x30~ 0x33,0x46,0x46" Offset Value (Rang 000~3ff) | "O" – Left Offset Command "SSS"- Offset Value (pixels) "nnn"- Return Value(pixels) |
| e.g Set Left Offset = 100 pixels (0x64 (HEX)) RS232 Code: "0xF0 0x4F 0x30 0x36 0x34" Return Code: "0xF0 0x4F 0x30 0x36 0x34 0x30 0x36 0x34" | | | |
| Text Window Horizontal Size | 0xF0, "X" "SSS" Return "nnn" | "X" = "0x58" Set Horizontal Size command ----- - "SSS" = "0x31,0x45,0x30~ 0x37,0x38,0x30" Horizontal Size Value (Rang 000~3ff) | "X" –Horizontal Size "SSS"- Size Value (pixels) "nnn"- Return Value(pixels) |
| e.g Set Text Window Horizontal Size = 640 pixels (0x280 (HEX)) RS232 Code: "0xF0 0x58 0x32 0x38 0x30" Return Code: "0xF0 0x58 0x32 0x38 0x30 0x32 0x38 0x30" | | | |
| Background Transparency | 0xF0, "B" "N" Return "n" | "B" = "0x42 or 0x62" Set Transparency command ----- "N" = "0x30~0x46" Transparency Value (Rang 00~0F) | "B" - Transparency command "N" – Transparency Value "n"- Return Value 0x00 =opaque |
| Set background Transparency value is 8 RS232 Code: "0xF0 0x42 0x38" Return Code: "0xF0 0x42 0x38 0x38" | | | |
| Text Overlay Background On or Off | 0xF0, "Q" "N" Return "n" | "Q" = "0x51 or 0x71" Set Background Enable or Disable ----- "N" = "0x30~0x31" | "B" - command "1" Turn On Text Overlay Background "0" Turn Off Text Overlay Background "n"- Return Value |
| Set background Transparency value is 8 RS232 Code: "0xF0 0x51 0x31" Return Code: "0xF0 0x51 0x31 0x31" | | | |

Please set the "Background Transparency" and "Left offset" commands before the "Send Line" command.

Display Mark Command

| Function | Command | Description | Acknowledge (if enabled) |
|---|--|--|---|
| Send Display Mark | 0xF1, "S" "0x21" "0x40" "0x60" "0x7E" Return "1" | "S" = "0x53 or 0x73" ASCII "0x21,0x40,0x60,0x7E" Return "0x31" | "S" – Send Command "Text" – Character "1" - successful. |
| e.g Send Display Mark RS232 Code: "0xF1 0x53 0x21" Return Code: "0xF1 0x53 0x21 0x31" | | | |
| Clear Display Mark | 0xF1, "C" Return "1" | "C" = "0x43 or 0x63" Return "0x31" | "C" – Clear command "1" - successful. |
| e.g Clear Display Mark RS232 Code: "0xF1 0x43" Return Code: "0xF1 0x43 0x31" | | | |
| Display Mark Horizontal Position | 0xF1, "H" "ss" Return "nn" | "H" = "0x48 or 0x68" ----- --"nn" = "0x30,0x30~0x46,0x46" | "H" – Horizontal Position command "ss" – Set Horizontal Position number "nn" – Return Position number |
| e.g Set Display Mark Horizontal Position RS232 Code: "0xF1 0x48 0x30 0x31" Return Code: "0xF1 0x48 0x30 0x31 0x30 0x31" | | | |
| Display Mark Vertical Position | 0xF1, "V" "ss" Return "nn" | "V" = "0x56 or 0x76" ----- --"nn" = "0x30,0x30~0x46,0x46" | "V" – Vertical Position command "ss" – Set Vertical Position number "nn" – Return Position number |
| e.g Set Display Mark Vertical Position RS232 Code: "0xF1 0x56 0x30 0x31" Return Code: "0xF1 0x56 0x30 0x31 0x30 0x31" | | | |
| Display Mark Background Transparency | 0xF1, "B" "N" Return "n" | "B" = "0x42 or 0x62" Set Transparency command ----- "N" = "0x30~0x46" Transparency Value (Rang 00~0F) | "B" - Transparency command "N" – Transparency Value "n"- Return Value 0x00 =opaque |
| Set Display Mark background Transparency value is 8 RS232 Code: "0xF1 0x42 0x38" Return Code: "0xF1 0x42 0x38 0x38" | | | |

The RS-232 command strings sent in one time can support up to 380 bytes via CN8 port
 The RS-232 command string sent in one time can support up to 50 bytes via CN1 or J1 port.

n = 1-byte ascii-coded hex number, e.g., parameter value of 0x1 is represented by “1” (0x31).
 mn or nn = 2-byte ascii-coded hex number, e.g., parameter value of 0x1e is represented by “1”, “e” | “E” (0x31, 0x6e|0x4e).

Please refer to the ASCII to Hex convert table below.

Hex to ASCII conversion table

| Hex | ASCII | Hex | ASCII | Hex | ASCII | Hex | ASCII |
|------|-------|------|-------|------|-------|------|-------|
| 0x30 | 0 | 0x41 | A | 0x61 | a | 0x2B | + |
| 0x31 | 1 | 0x42 | B | 0x62 | b | 0x2D | - |
| 0x32 | 2 | 0x43 | C | 0x63 | c | 0x3F | ? |
| 0x33 | 3 | 0x44 | D | 0x64 | d | | |
| 0x34 | 4 | 0x45 | E | 0x65 | e | | |
| 0x35 | 5 | 0x46 | F | 0x66 | f | | |
| 0x36 | 6 | 0x47 | G | 0x67 | g | | |
| 0x37 | 7 | 0x48 | H | 0x68 | h | | |
| 0x38 | 8 | 0x49 | I | 0x69 | i | | |
| 0x39 | 9 | 0x4A | J | 0x6A | j | | |
| | | 0x4B | K | 0x6B | k | | |
| | | 0x4C | L | 0x6C | l | | |
| | | 0x4D | M | 0x6D | m | | |
| | | 0x4E | N | 0x6E | n | | |
| | | 0x4F | O | 0x6F | o | | |
| | | 0x50 | P | 0x70 | p | | |
| | | 0x51 | Q | 0x71 | q | | |
| | | 0x52 | R | 0x72 | r | | |
| | | 0x53 | S | 0x73 | s | | |
| | | 0x54 | T | 0x74 | t | | |
| | | 0x55 | U | 0x75 | u | | |
| | | 0x56 | V | 0x76 | v | | |
| | | 0x57 | W | 0x77 | w | | |
| | | 0x58 | X | 0x78 | x | | |
| | | 0x59 | Y | 0x79 | y | | |
| | | 0x5A | Z | 0x7A | z | | |

Appendix I – Mapping definition

- Definition of Mapping A :

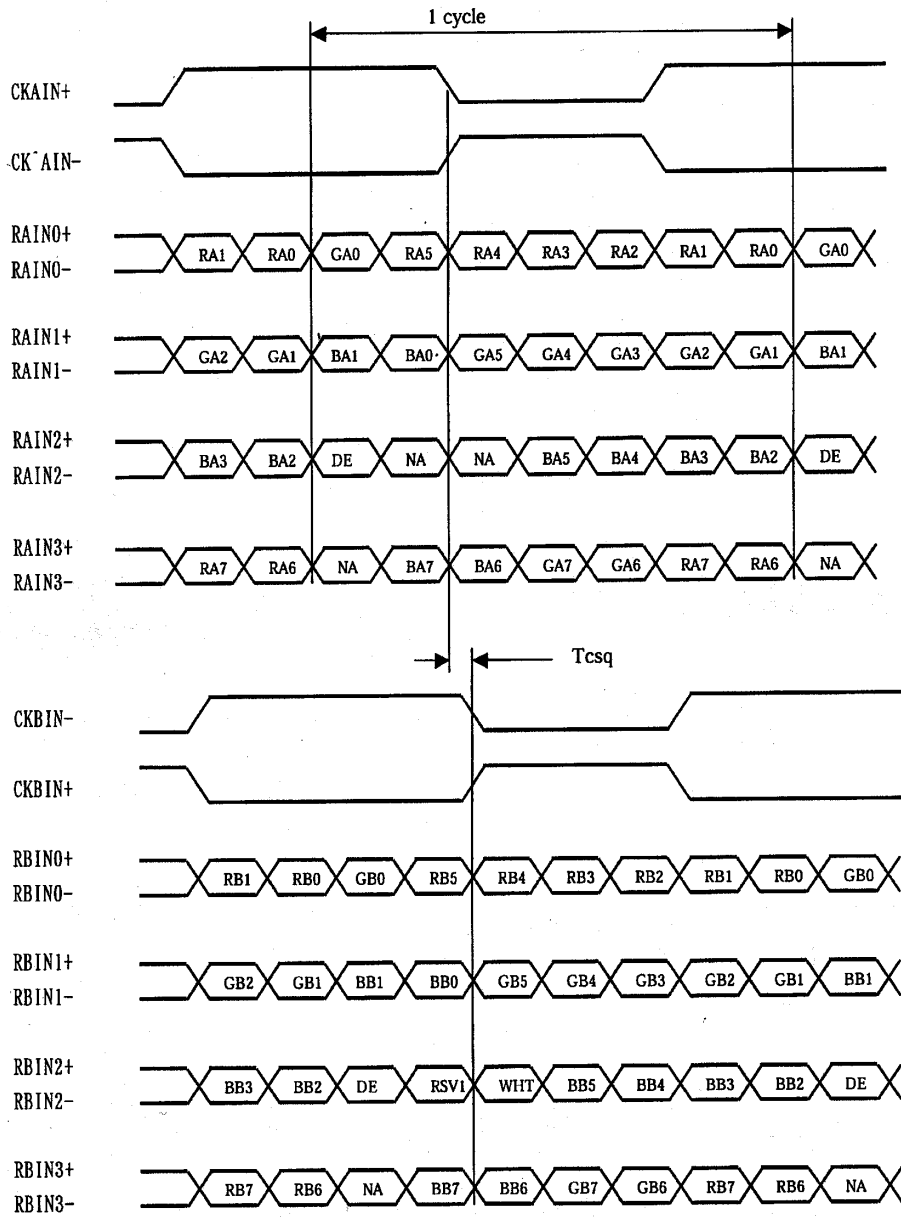

- Definition of Mapping B :

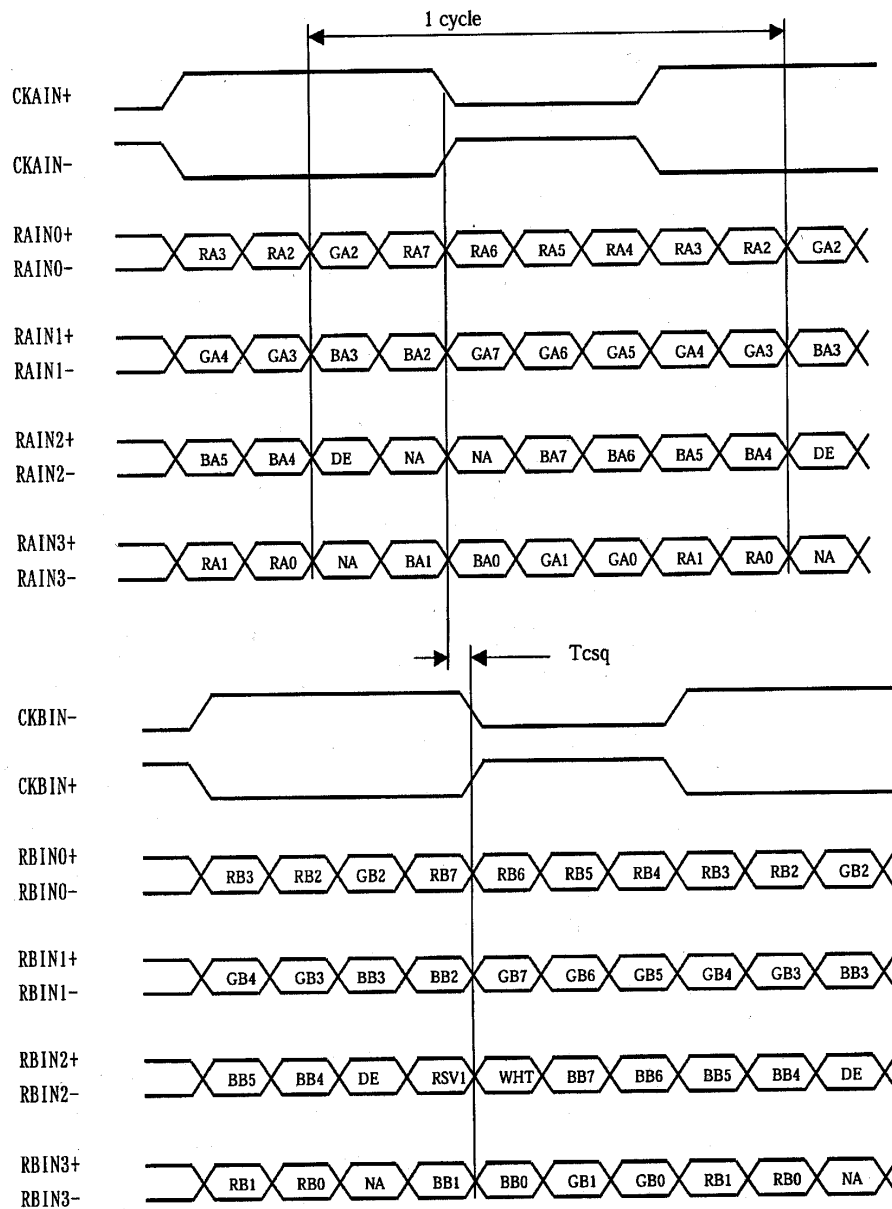

- Definition of VESA :

| DPort Output Pair | Bit 6 | Bit 5 | Bit 4 | Bit 3 | Bit 2 | Bit 1 | Bit 0 |
|-------------------|-----------|-------|-------|-------|-------|-------|-------|
| DB[7:6] / TXDEC | | | | | | | |
| DB[3:2] / TXDE0 | GE0 | RE5 | RE4 | RE3 | RE2 | RE1 | RE0 |
| DB[5:4] / TXDE1 | BE1 | BE0 | GE5 | GE4 | GE3 | GE2 | GE1 |
| DB[9:8] / TXDE2 | EN | VS | HS | BE5 | BE4 | BE3 | BE2 |
| DG[3:2] / TXDE3 | field/prg | BE7 | BE6 | GE7 | GE6 | RE7 | RE6 |
| DG[5:4] / TXDE4 | low | BE9 | BE8 | GE9 | GE8 | RE9 | RE8 |
| DG[7:6] / TXDO0 | GO0 | RO5 | RO4 | RO3 | RO2 | RO1 | RO0 |
| DG[9:8] / TXDO1 | BO1 | BO0 | GO5 | GO4 | GO3 | GO2 | GO1 |
| DR[5:4] / TXDO2 | EN | VS | HS | BO5 | BO4 | BO3 | BO2 |
| DR[7:6] / TXDO3 | field/prg | BO7 | BO6 | GO7 | GO6 | RO7 | RO6 |
| DR[9:8] / TXDO4 | low | BO9 | BO8 | GO9 | GO8 | RO9 | RO8 |
| DR[3:2] / TXDOC | | | | | | | |

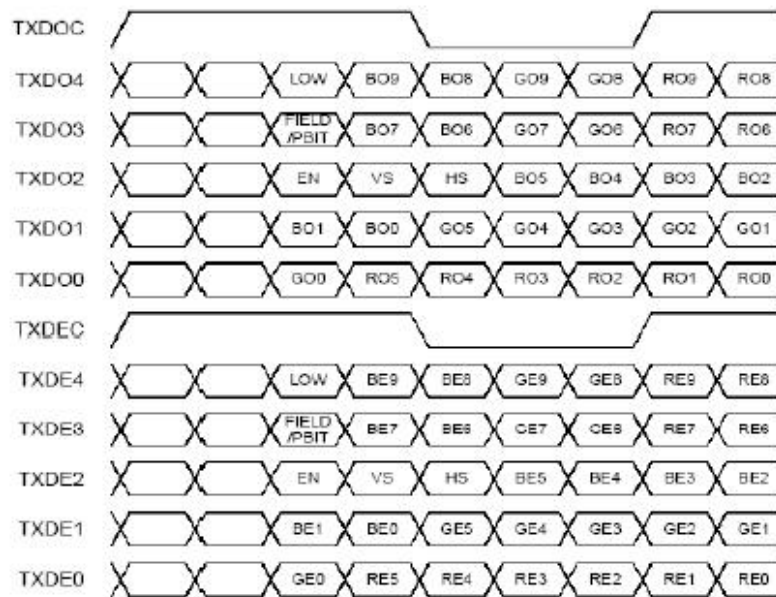

- Definition of JEIDA :

| DPort Output Pair | Bit 6 | Bit 5 | Bit 4 | Bit 3 | Bit 2 | Bit 1 | Bit 0 |
|-------------------|-----------|-------|-------|-------|-------|-------|-------|
| DB[7:6] / TXDEC | | | | | | | |
| DB[3:2] / TXDE0 | GE4 | RE9 | RE8 | RE7 | RE6 | RE5 | RE4 |
| DB[5:4] / TXDE1 | BE5 | BE4 | GE9 | GE8 | GE7 | GE6 | GE5 |
| DB[9:8] / TXDE2 | EN | VS | HS | BE9 | BE8 | BE7 | BE6 |
| DG[3:2] / TXDE3 | field/prg | BE3 | BE2 | GE3 | GE2 | RE3 | RE2 |
| DG[5:4] / TXDE4 | low | BE1 | BE0 | GE1 | GE0 | RE1 | RE0 |
| DG[7:6] / TXDO0 | GO4 | RO9 | RO8 | RO7 | RO6 | RO5 | RO4 |
| DG[9:8] / TXDO1 | BO5 | BO4 | GO9 | GO8 | GO7 | GO6 | GO5 |
| DR[5:4] / TXDO2 | EN | VS | HS | BO9 | BO8 | BO7 | BO6 |
| DR[7:6] / TXDO3 | field/prg | BO3 | BO2 | GO3 | GO2 | RO3 | RO2 |
| DR[9:8] / TXDO4 | low | BO1 | BO0 | GO1 | GO0 | RO1 | RO0 |
| DR[3:2] / TXDOC | | | | | | | |

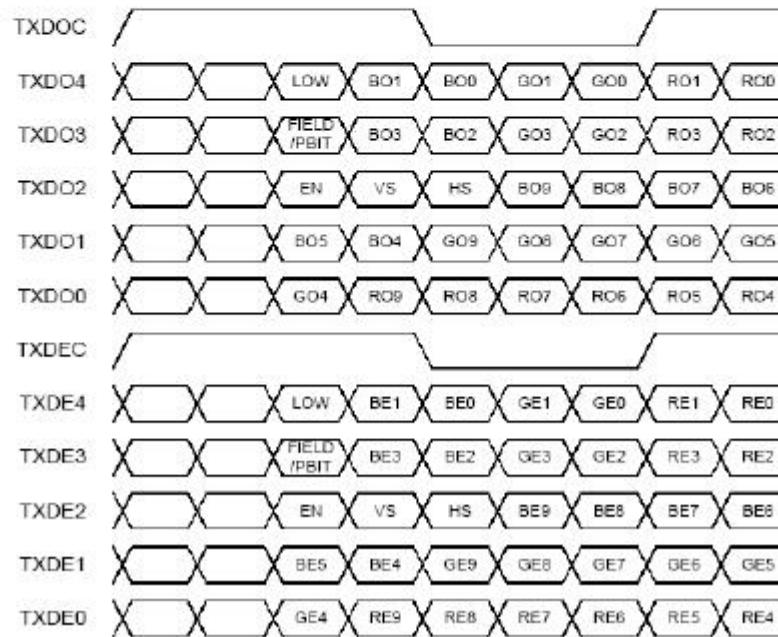

Appendix IV – Auto Color Gain

The Auto Color Gain function is supported in the ARGB mode only and is designed to calibrate the controller to the incoming video signal. In order to calibrate correctly, the display must be displaying an image containing both black and white data (see illustration below) when the function is used. The internal processor of the video controller chip will then execute a process to adjust the relative values of the RGB signals to achieve the best performance. The parameters of the corrected RGB values are then stored in the controller and are unaffected by the Reset Factory Defaults function.

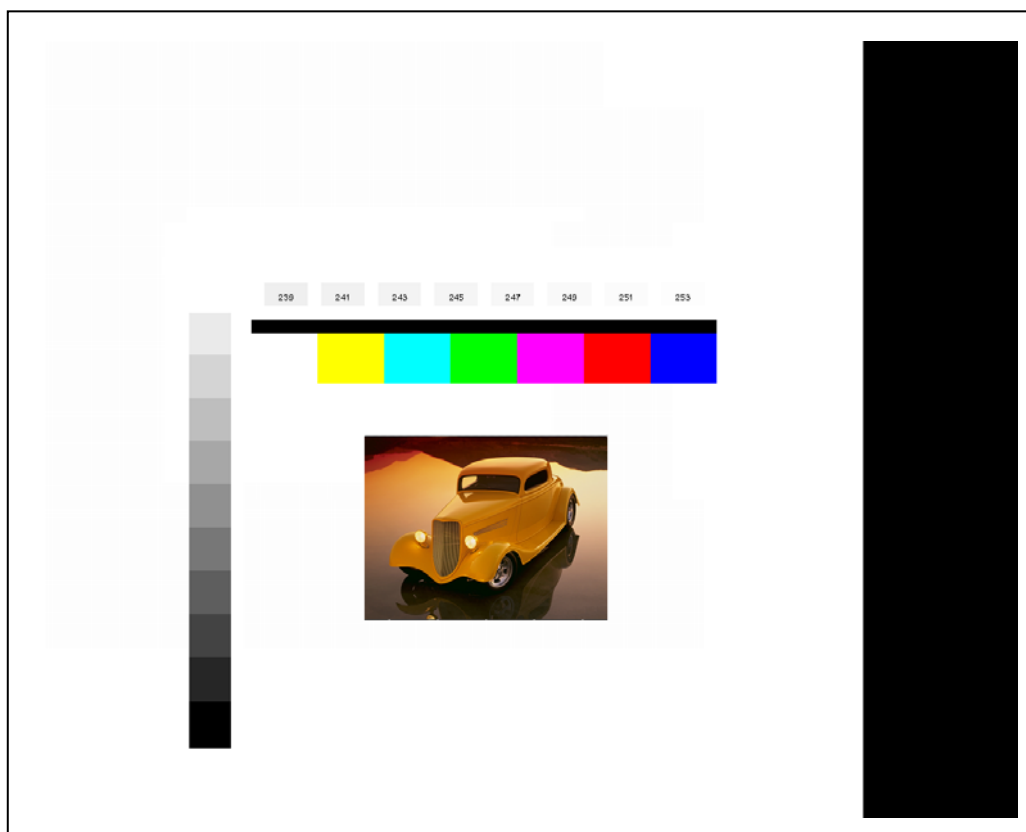

The reference pattern can be downloaded at :

http://www.digitalview.com/support/downloads/TestPattern_1280.BMP

This reference pattern is for 1280x1024 resolution and it needs to set your ARGB input source to 1280x1024 resolution before performing the Auto Color Gain function. The position of the black vertical bar in the pattern at the right side is important. It will affect the calibration result if you are setting the ARGB input to other resolution.

Warning - If the Auto Color Gain is executed without an appropriate image being displayed, then the process will set incorrect values and the display colors will be distorted. If this occurs, then it can either be corrected by performing the process correctly or if this is not possible then the Reset Color Gain function can be used. This function will reset the stored RGB values to a set of approximate values.

Appendix V – DV remote control unit work for SGX-1920

P/N 559000106-3 :
DigitalView remote control unit
(without DV logo silk screen
printing)

P/N 559000105-3 :
DigitalView remote control unit
(with DigitalView logo silk
screen printing)



| BUTTON | FUNCTION |
|----------------------------|--|
| POWER BUTTON | Soft power ON/OFF button. |
| ATTENTION BUTTON | Use combined with digit keys to enable/disable the IR function. SGX-1920 : "Attention" + "1" |
| MUTE BUTTON (MUTE) | Switch to mute on/off mode. |
| AV/TV BUTTON | Use to select the input source. (VGA/DVI/HDMI/..) |
| SOUND (ZOOM) BUTTON | Use to display the zoom menu. Press the "+" to zoom in the picture and the "-" to zoom out the picture. |
| PIP BUTTON | Use to select the PIP (Picture in Picture) setting |
| SEL UP (▲) / SEL DN (▼) | Use this button to direct control the hotkey function. Press the "SEL UP" button to increase the pre-set hotkey parameter value and the "SEL DN" button to decrease the pre-set hotkey parameter value. In OSD menu, pressing this button to select the items. |
| VOLUME (-/+) BUTTON | Press the "+" button to increase the volume and the "-" to decrease the volume. |
| + / - BUTTON | Use this button to direct control the hotkey function. Press the "+" button to increase the pre-set hotkey parameter value and the "-" button to decrease the pre-set hotkey parameter value. In OSD menu, pressing this button to adjust the settings. |
| OSD BACK BUTTON | Use to display the OSD menu and go to the previous OSD screen. |
| OSD NEXT BUTTON | Use to display the OSD menu and go to the next OSD screen. |
| DISPLAY BUTTON | Use to view an on-screen information. When OSD menu displayed, press this button to turn it off. |
| TRACK (S-Video) BUTTON | Press this button in the non OSD menu display mode to select S-Video 1 source. |
| TRACK (Composite 1) BUTTON | Press this button in the non OSD menu display mode to select Composite 1 source. |
| Composite 2 BUTTON | Press this button in the non OSD menu display mode to select Composite 2 source. |
| PLAY (YPbPr) BUTTON | Press this button in the non OSD menu display mode to select Component 1 source. |
| STOP (VGA) BUTTON | Press this button in the non OSD menu display mode to select VGA source. |
| FREEZE (II) BUTTON | Use this button to freeze and release the picture on your screen. |
| DVI BUTTON | Press this button in the non OSD menu display mode to select DVI source. |
| HDMI BUTTON | Press this button in the non OSD menu display mode to select HDMI source. |
| HDSDI1 BUTTON | Press this button in the non OSD menu display mode to select HD-SDI 1 source. |
| HDSDI2 BUTTON | Press this button in the non OSD menu display mode to select HD-SDI 2 source. |

Specifications subject to change without notice

Appendix VI – Function description for de-interlacing mode AFM, TNR, MADi, DCDi

AFM = Auto Film Mode :

It is a frame based method which used for the input ODD and EVEN fields have a fixed relation between each other, such as static image, 3:2 pull down mode.

If two fields are correctly merged, it can get the best quality. But if it merges two wrong fields, it will have artifact and get the worst quality.

TNR = Temporal Noise Reduction :

It is a frame based method which assume field to field have a fixed relationship.

If the object moving too fast, it will have image artifact and get worst quality.

MADi = Motion adaptive de-interlacing :

It is a pixel based method which used for the input fields have no fixed relation between them

If the object moving very too fast, it will get worst quality.

DCDi = Directional Correlation Deinterlacing :

It is a digital enhancement method developed by Faroudja. DCDi technology is primarily used for improving the image quality of low resolution images. This is done by deinterlacing the image and blending rough edges occurring in diagonal lines.

Appendix VII – PIP mix table

| | | INPUT SOURCES | | | | | | | | |
|--------------|---------------------------|---------------|-------------|-------------|-----------|-----------|-------------|-------------|--------------------------|---------------------------|
| | | VGA | Composite 1 | Composite 2 | S-Video 1 | S-Video 2 | Component 1 | Component 2 | DVI / Auxiliary port HD1 | HDMI / Auxiliary port HD2 |
| INPUT SOURCE | VGA | X | ✓ | ✓ | ✓ | ✓ | ✓ | ✓ | ✓ | ✓ |
| | Composite 1 | ✓ | X | ✓ | ✓ | ✓ | ✓ | ✓ | ✓ | ✓ |
| | Composite 2 | ✓ | ✓ | X | ✓ | ✓ | ✓ | ✓ | ✓ | ✓ |
| | S-Video 1 | ✓ | ✓ | ✓ | X | ✓ | ✓ | ✓ | ✓ | ✓ |
| | S-Video 2 | ✓ | ✓ | ✓ | ✓ | X | ✓ | ✓ | ✓ | ✓ |
| | Component 1 | ✓ | ✓ | ✓ | ✓ | ✓ | X | ✓ | ✓ | ✓ |
| | Component 2 | ✓ | ✓ | ✓ | ✓ | ✓ | ✓ | X | ✓ | ✓ |
| | DVI / Auxiliary port HD1 | ✓ | ✓ | ✓ | ✓ | ✓ | ✓ | ✓ | X | ✓ |
| | HDMI / Auxiliary port HD2 | ✓ | ✓ | ✓ | ✓ | ✓ | ✓ | ✓ | ✓ | X |

Appendix VIII – Network connection

The SGX-1920 LCD interface controller has an RJ-45 Ethernet port for control and monitoring over a network. This application note introduces the two user interface modes:

- Browser based web server mode
- Command line direct mode (this is the default mode)

There is also a short overview of the command set and how it is implemented.

QUICK GUIDE

For experienced users the following quick guide to trying out the network connection and functions may be useful.

- The SGX-1920 ships with the browser based web-server mode installed as default.
- Works with a normal network with DHCP, i.e. must use a router.
- Connect the SGX-1920 to the network and ensure power is on.
- Use the IP-50 IP Locator utility available from the IP-50 web-page.
<http://www.digitalview.com/media/downloads/IPLocator.zip> (Windows only)
- Double click on the IP address in the IP Locator window, it will open the SGX-1920 browser page in your default browser. Alternatively copy the IP address into your browser address line.
- Test the functions that come up on the browser.

Command line direct mode: This is relevant when a PC application is used to send and receive commands over the network port. The network port will require an alternative firmware version if the Command line direct mode is required.

For details, please refer to the separate application note.

Appendix IX – Digital Ports selection on SGX-1920

Port definition :

P2 : DVI

P3 : HDMI

HD1 : Auxiliary digital input port

HD2 : Auxiliary digital input port

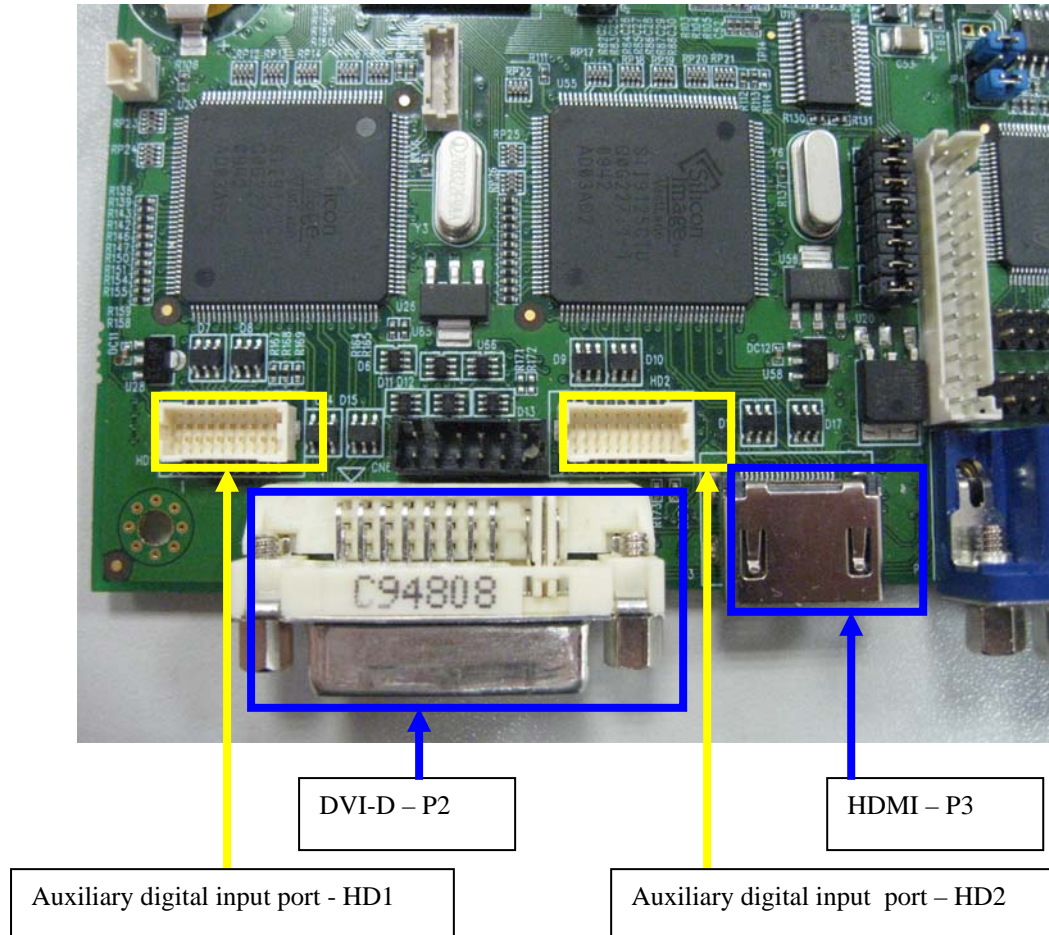

(1) SGX-1920 without connect any I²C control on CN8 (i.e : HD-1000/-2000/-3000S/-3000)

(i) The board allows the user to configure the digital signal path via P2, P3, HD1, HD2.

Press and hold "MENU" button on the OSD switch mount and turn on the controller to enter the "Programming mode".

Choose "Auxiliary Port Select" shown below :

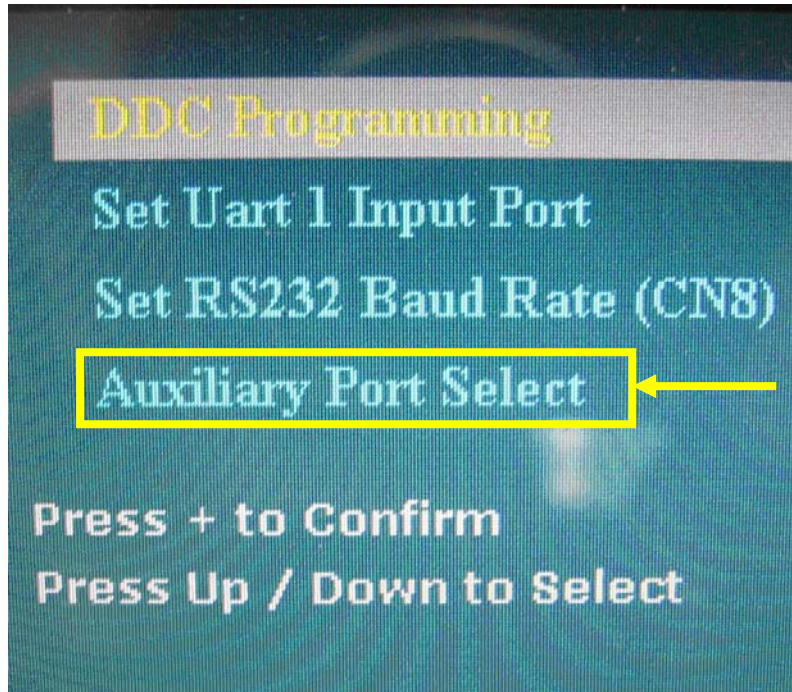

(ii) Choose Digital signal port path :

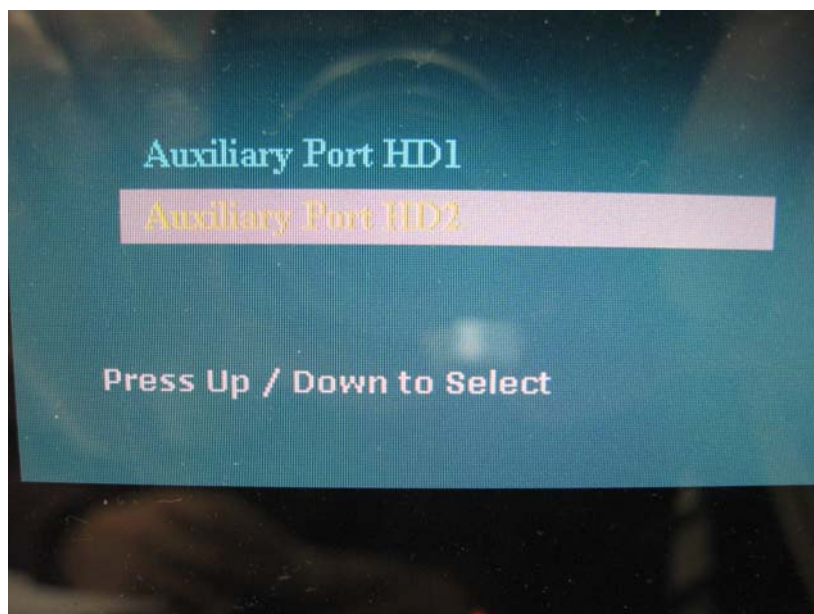

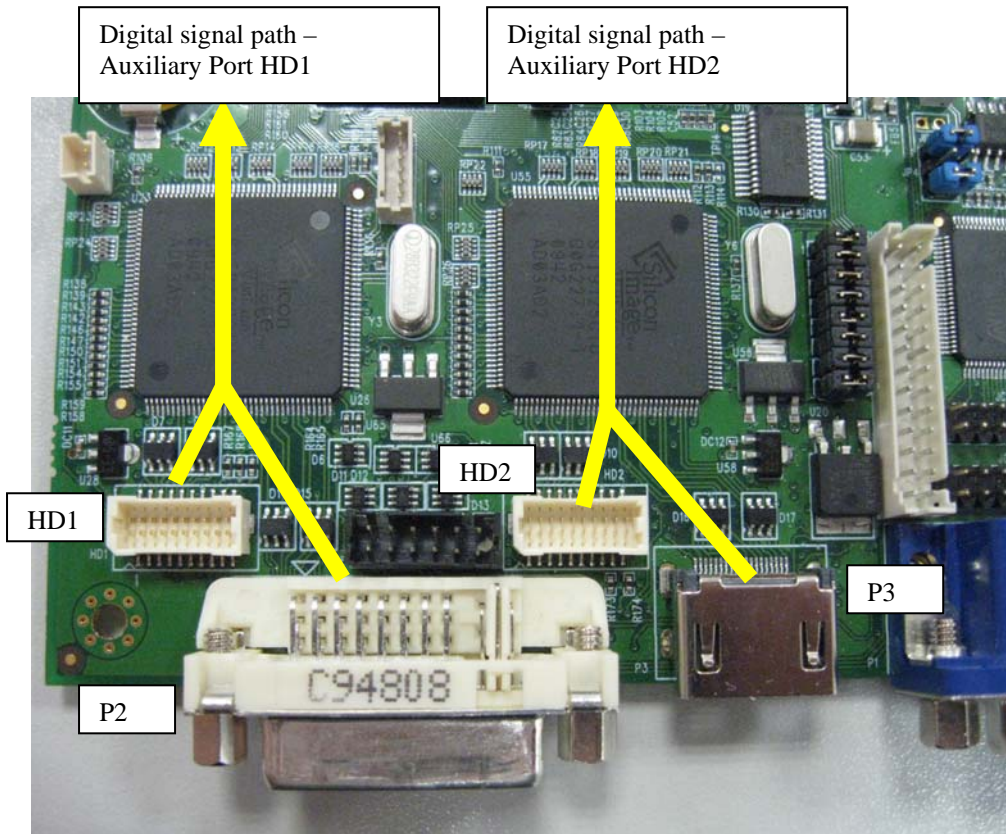

(iii) Choose the Auxiliary port HD1/HD2 configuration selection :

Auxiliary port HD1 :

1. Set DVI Input from HD1 : Input DVI signal from HD1 port and disable P2 (DVI) port.
2. Set DVI Input from P2 : Input DVI signal from P2 (DVI) port and disable HD1.

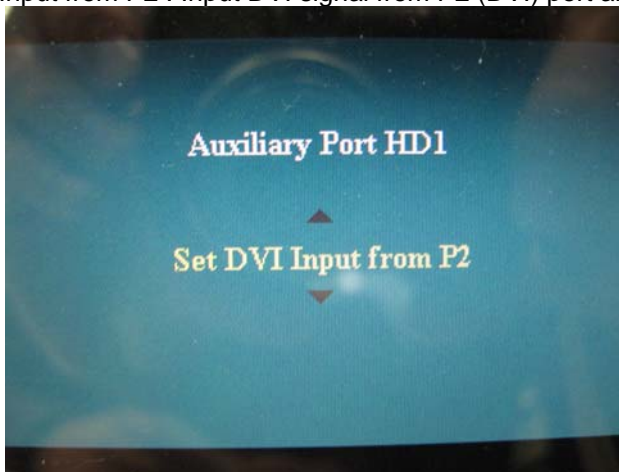

Auxiliary port HD2 :

1. Set HDMI input from HD2 : Input HDMI signal from HD2 port and disable P3 (HDMI) port.
2. Set HDMI Input from P3 : Input HDMI signal from P3 (HDMI) port and disable HD2.

(2) SGX-1920 connect with HD-1000/-2000/-3000S via I²C control on CN8

(i) The board allows the user to configure the digital signal path via P2, P3, HD1, HD2.

Press and hold "MENU" button on the OSD switch mount and turn on the controller to enter the "Programming mode".

Choose "Auxiliary Port Select" shown below :

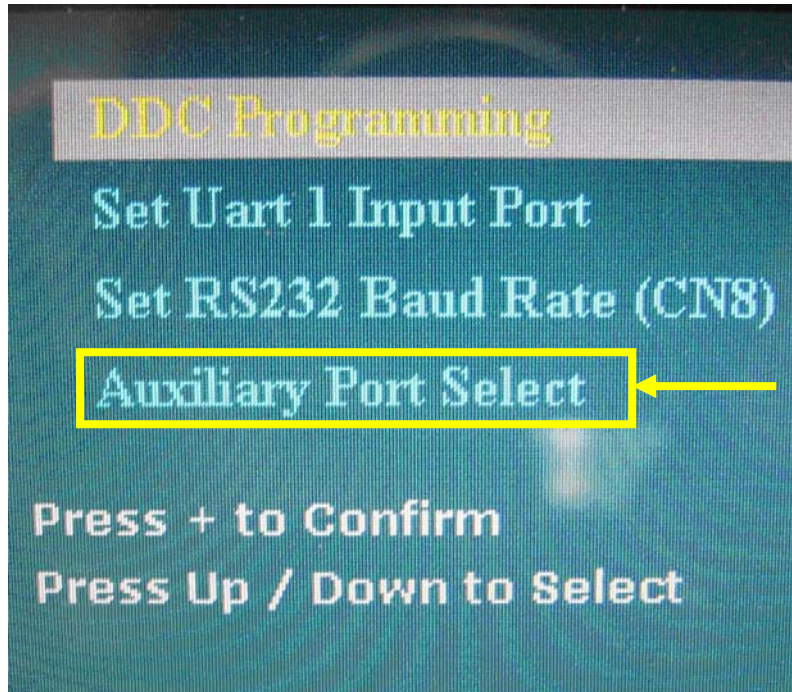

(ii) Choose Digital signal port path :

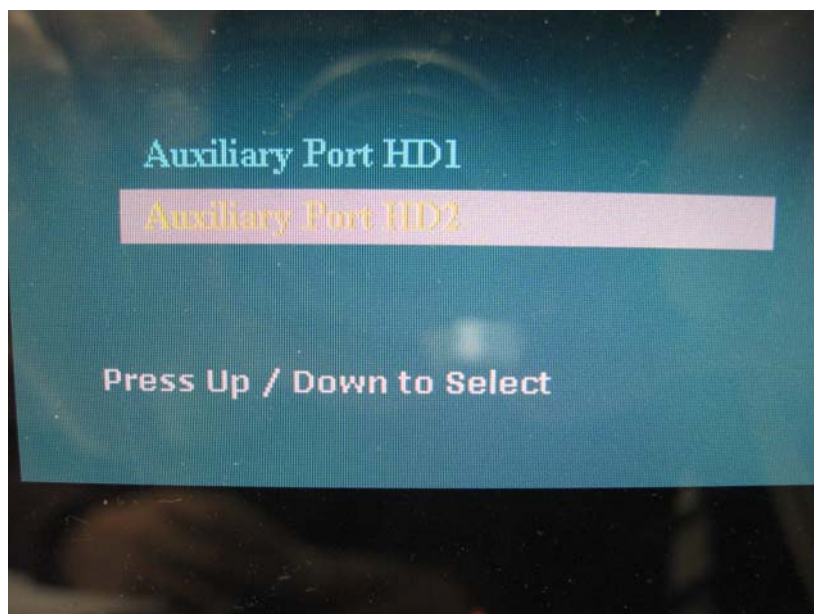

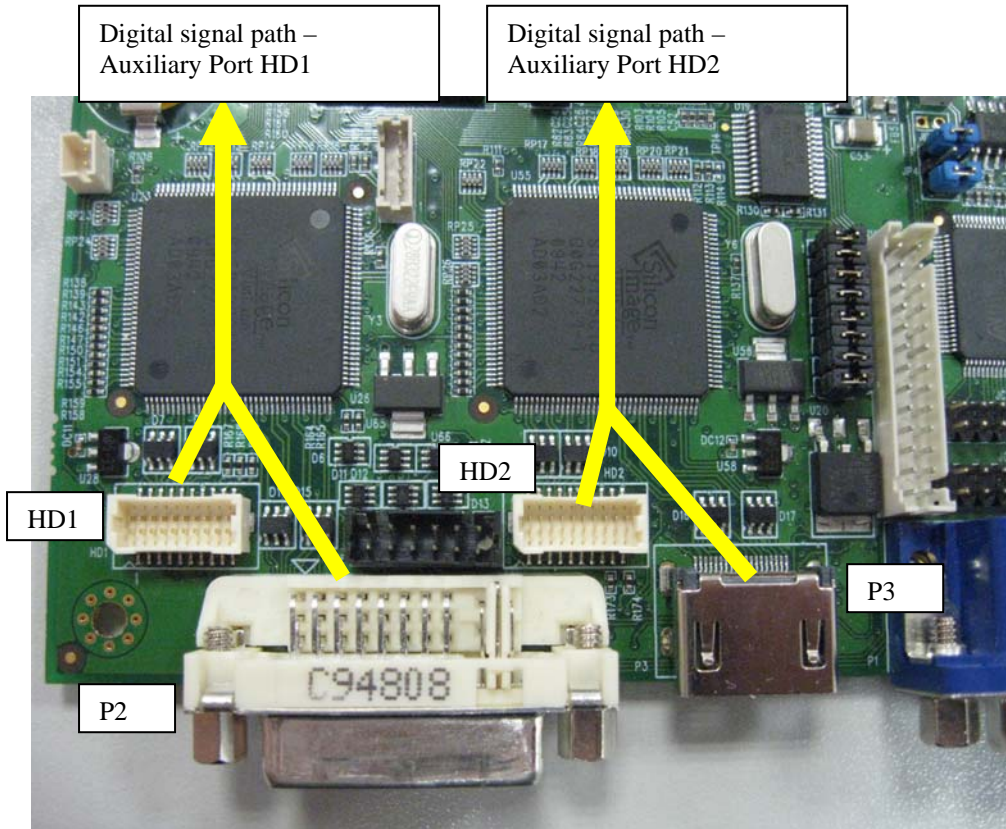

(iii) Choose the Auxiliary port HD1/HD2 configuration selection :

Auxiliary port HD1 :

1. Set HD/SDI Input from HD1 : Input digital signal coming from HD-1000/-2000/-3000S to HD1 port and disable P2 (DVI) port.
2. Set HD/SDI Input from P2 : Input digital signal coming from HD-1000/-2000/-3000S to P2 (DVI) port and disable HD1 port.
3. Set DVI Input from P2 : Input DVI signal from P2 (DVI) and disable HD1 port.

Auxiliary port HD2 :

1. Set HD/SDI Input from HD2 : Input digital signal coming from HD-1000/-2000/-3000S to HD2 port and disable P3 (HDMI) port.
2. Set HD/SDI Input from P3 : Input digital signal coming from HD-1000/-2000/-3000S to P3 (HDMI) port and disable HD2 port.
3. Set HDMI Input from P3 : Input DVI signal from P3 (HDMI) port and disable HD2 port.

*** The controller will factory default to HD2 for digital signal coming from HD-1000/-2000/-3000S

(3) SGX-1920 connect with HD-3000 via I²C control on CN8

The controller will disable P2 (DVI) & P3 (HDMI) port and enable HD1 for HD-SDI 1 input & enable HD2 for HD-SDI 2 input automatically when connect with HD-3000 via I²C control on CN8.

Appendix X - Inverter Interface Board P/N 416040010-3
[OPERATE UNDER 12VDC POWER INPUT ENVIRONMENT]

The Inverter interface board provides interface to drive up the high current consumption panel inverter in excess of 3.5A. This board enables current of up to 8 Amps to be managed safely while retaining the capability for inverter dimming and management of the inverter enable signal according to VESA DPMS standards. Additionally, the inverter interface board provides over-voltage protection via a resettable fuse when the input voltage exceeds 13V and reverse polarity protection against accidental misconnection.

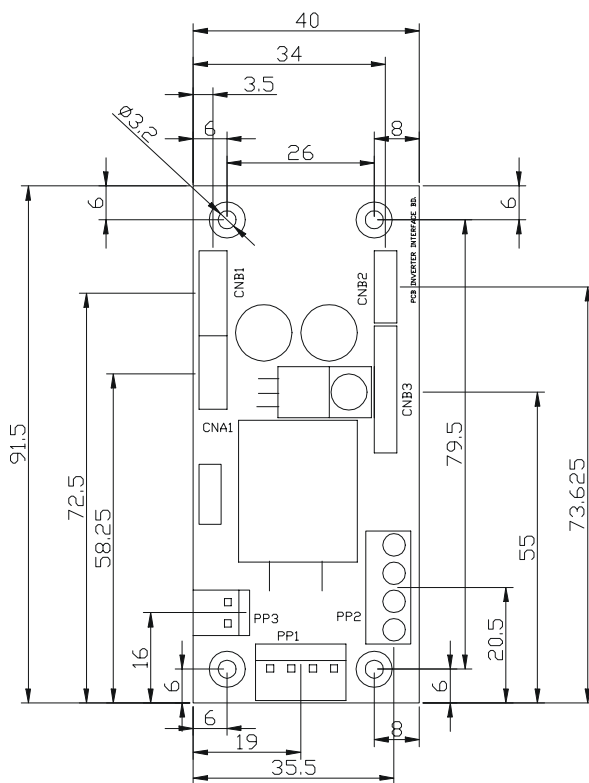

- Connector Type :**
 CNA1, CNB2 : JST 4 ways, B4B-XH-A
 CNB1 : JST 5 ways, B5B-XH-A
 CNB3 : JST 8 ways, B8B-XH-A
 PP1 : PWR 4 way
 PP2 : Terminal Block 2 poles x 2
 PP3 : PWR 2 ways

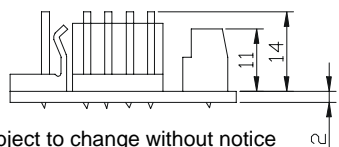

Specifications subject to change without notice

Illustrated Diagram

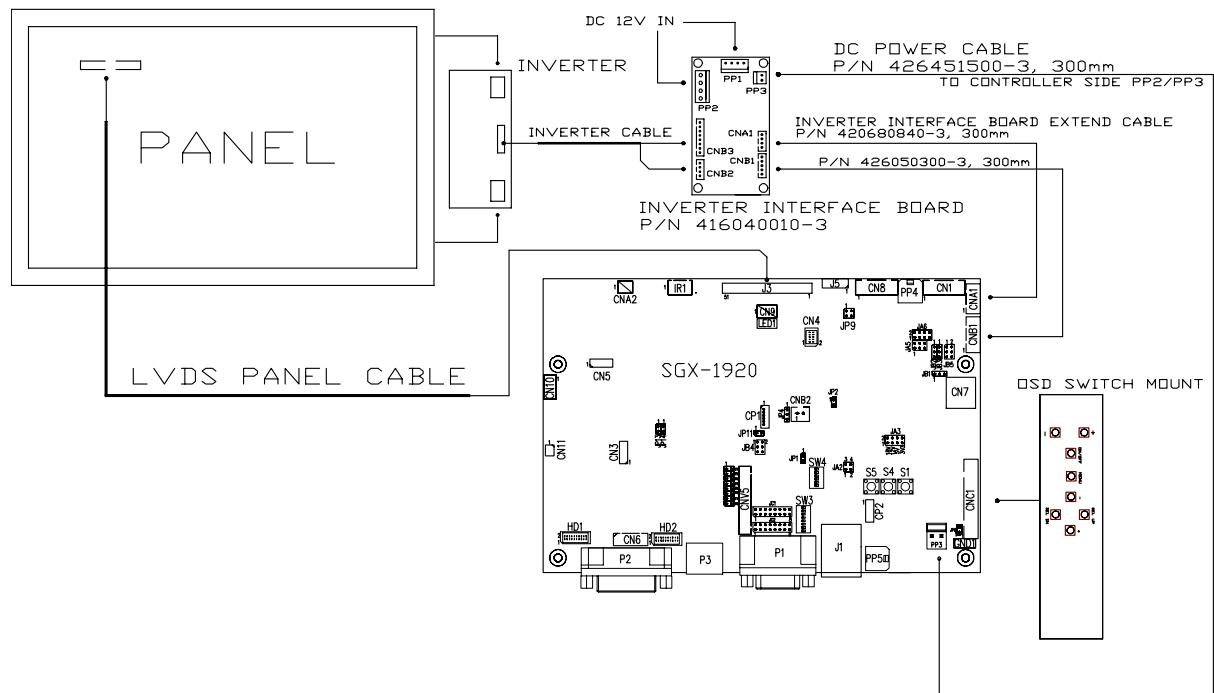

PP1 - 12VDC power supply – input, Power header 4 ways 0.156” pitch

| PIN | DESCRIPTION |
|-----|-------------|
| 1 | +12VDC |
| 2 | +12VDC |
| 3 | Ground |
| 4 | Ground |

PP2 – Alternate 12VDC power supply – input, Terminal Block 2 poles

| PIN | DESCRIPTION |
|-----|-------------|
| 1 | +12VDC |
| 2 | +12VDC |
| 3 | Ground |
| 4 | Ground |

PP3 – 12VDC power supply to controller – Output, Power header 2 ways, 0.156” pitch

| PIN | DESCRIPTION |
|-----|-------------|
| 1 | +12VDC |
| 2 | Ground |

CNA1 - Inverter interface to controller, JST B4B-XH-A

| PIN | SYMBOL | DESCRIPTION |
|-----|---------|-------------------|
| 1 | NC | No connection |
| 2 | AUX_GND | Ground |
| 3 | AUX_GND | Ground |
| 4 | AUX_Vcc | +5V DC, 500mA max |

CNB1 – Inverter interface to controller, JST B5B-XH-A

| PIN | SYMBOL | DESCRIPTION |
|-----|---------|---------------------------------|
| 1 | GND | Ground |
| 2 | BL_ON | Backlight power |
| 3 | BLCTRL | Backlight on/off control signal |
| 4 | BVR_WIP | Backlight brightness VR pin WIP |
| 5 | BVR_A | Backlight brightness VR pin A |

CNB2 – Inverter interface to backlight inverter, JST B4B-XH-A

| PIN | SYMBOL | DESCRIPTION |
|-----|---------|-------------------|
| 1 | VLCD12 | Panel power |
| 2 | AUX_GND | Ground |
| 3 | AUX_GND | Ground |
| 4 | AUX_Vcc | +5V DC, 500mA max |

CNB3 – Inverter interface to backlight inverter, JST B8B-XH-A

| PIN | SYMBOL | DESCRIPTION |
|------------|---------------|---------------------------------|
| 1 | VLCD12 | Panel power |
| 2 | VLCD12 | Panel power |
| 3 | GND | Ground |
| 4 | GND | Ground |
| 5 | VLCD12 | Panel power |
| 6 | BLCTRL | Backlight on/off control signal |
| 7 | BVR_WIP | Backlight brightness VR pin WIP |
| 8 | BVR_A | Backlight brightness VR pin A |

Appendix XI - Audio Add-on Board P/N 416940020-3
[OPERATE UNDER 12VDC POWER INPUT ENVIRONMENT]

The Audio add-on board P/N 416940020-3 design for connection with DV controllers on the audio connector CN7. It provides audio input ports and output port for sound amplification.



Electrical Specification :

Supply Voltage : +12V, +5V
 Supply current : 35mA for +12V, 6mA for +5V

Input impedance 6.8kohm
 Output power : 2.0W for 4ohm load
 1.0W for 8ohm load

Distortion : <2%
 Voltage gain : 0 to 21 dB

Use of connectors :

| Connector | Connector type |
|-----------|--|
| CN1 | JST B3B-XH-A |
| CN2 | JST B4B-PH-K |
| CN3 | 0.1 inches 2 row x 5 pin header strips (right angle) |
| J1 | Ø3.5mm stereo jack socket |
| J2 | Ø3.5mm stereo jack socket |

Pin Assignments :

CN1: Output alternate connector

| Pin Number | Description |
|------------|-------------------|
| 1 | Speaker out left |
| 2 | Ground |
| 3 | Speaker out right |

CN2: Input alternate connector

| Pin Number | Description |
|------------|-------------------|
| 1 | Ground |
| 2 | Audio input left |
| 3 | Ground |
| 4 | Audio input right |

WARRANTY

The products are warranted against defects in workmanship and material for a period of three (3) year from the date of purchase provided no modifications are made to it and it is operated under normal conditions and in compliance with the instruction manual.

The warranty does not apply to:

- Product that has been installed incorrectly, this specifically includes but is not limited to cases where electrical short circuit is caused.
- Product that has been altered or repaired except by the manufacturer (or with the manufacturer's consent).
- Product that has subjected to misuse, accidents, abuse, negligence or unusual stress whether physical or electrical.
- Ordinary wear and tear.

Except for the above express warranties, the manufacturer disclaims all warranties on products furnished hereunder, including all implied warranties of merchantability and fitness for a particular application or purpose. The stated express warranties are in lieu of all obligations or liabilities on the part of the manufacturer for damages, including but not limited to special, indirect consequential damages arising out of or in connection with the use of or performance of the products.

CAUTION

Whilst care has been taken to provide as much detail as possible for use of this product it cannot be relied upon as an exhaustive source of information. This product is for use by suitably qualified persons who understand the nature of the work they are doing and are able to take suitable precautions and design and produce a product that is safe and meets regulatory requirements.

LIMITATION OF LIABILITY

The manufacturer's liability for damages to customer or others resulting from the use of any product supplied hereunder shall in no event exceed the purchase price of said product.

TRADEMARKS

The following are trademarks of Digital View Ltd:

- Digital View
- SGX-1920

CONTACT DETAILS

Digital View has offices in Asia, Europe and USA :

USA

Digital View Inc.
18440 Technology Drive
Building 130
Morgan Hill,
California, 95037
USA

Tel: (1) 408-782 7773 **Fax:** (1) 408-782 7883

Sales: ussales@digitalview.com

EUROPE

Digital View Ltd.
The Lake House
Knebworth Park
Herts, SG3 6PY
UK

Tel: +44-(0)20-7631-2150 **Fax:** +44-(0)20-7631-2156

Sales: uksales@digitalview.com

ASIA

Digital View Ltd
16 th Floor Millennium City 3
370 Kwun Tong Road
Kwun Tong
Hong Kong

Tel: (852) 2861 3615 **Fax:** (852) 2520 2987

Sales: hksales@digitalview.com

WEBSITE

www.digitalview.com